

# Chapter 5

## Charge Controllers and Load Management

*This chapter discusses charge controllers, devices which are used to manage the energy flow in solar electric systems. The work of charge controllers is described, and controller components are introduced, including fuses, main switches, blocking diodes, LED indicators, low voltage disconnects, and charge regulators. The choice of charge controllers in East Africa is briefly described. Management of small systems without charge controllers is also considered.*

As explained in Chapter 4, the success of a solar electric lighting system depends, to a large extent, on the performance of the batteries. For a system to operate well and have a long lifetime, the batteries must be kept in as high a state of charge as possible. The energy entering the batteries during the day (i.e. the solar charge), must be roughly equivalent to the energy being discharged from the batteries at night by the load.

Any solar electric lighting system must be managed so that the energy flow from the batteries to the load is not too great, and so that the energy flow into the batteries from the modules is not too great. Most solar electric systems use a charge controller to manage the electrical power produced by

the modules, and to act as a connection point for all the system components. To save money, some designers of small lighting systems do not include charge controllers in the system, and instead rely on the user to manage the energy flow.

### The Charge Controller

The charge controller, or control panel (as it is sometimes called), has two primary functions. First, it provides a central point for connecting the load, the module and the battery. Secondly, it manages the system so that the harvested electricity is effectively used, and so that components are protected from damage due to changing voltage levels.

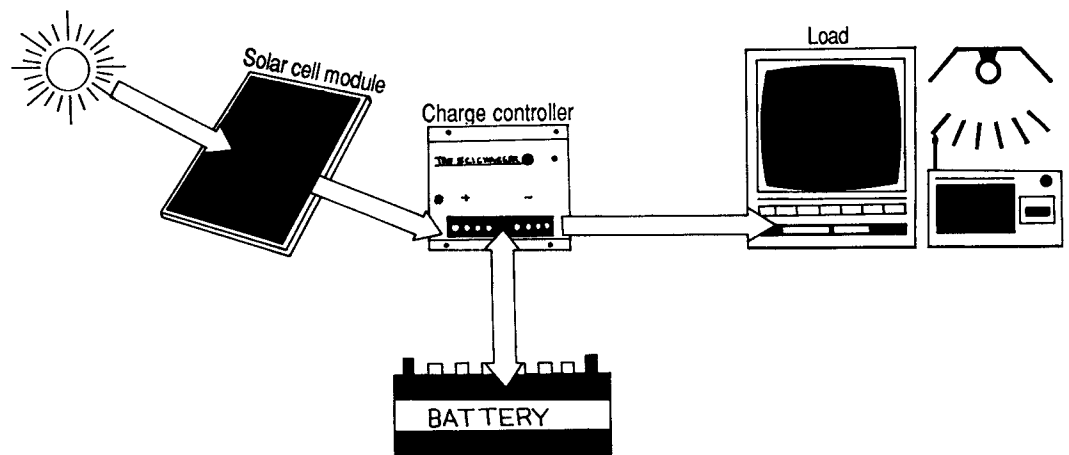
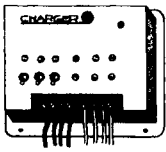

Figure 5.1: Role of a charge controller in energy management



## Charge Controllers and Load Management

The charge controller provides a central point for connecting the load, module, and battery. It also manages the system so that harvested electricity is effectively used.

### System Connections

The control panel, at the very least, should act as a *junction box*. Here, the battery, solar module and load are fastened together by means of connector strips, and fuses are incorporated to protect the equipment from damage by *short circuits*.

**Fuses and circuit breakers.** The controller should contain the system *fuses* or *miniature circuit breakers (MCB's)*. Fuses and circuit breakers protect the major circuits in the system from short circuits. Simple automotive-type fuses or fuse wires are readily available in East Africa. Five amp fuses are sufficient for very small systems, while 20 amp fuses (or larger) are necessary for larger systems. MCB's are small switches that automatically break the circuit when there is a short circuit. They can be switched back ON when the wiring problem is corrected. Both the charge wire from the solar cell and the load wires (to the lights and to other loads) should be fused or protected by an MCB.

### Main circuit switches.

It may be necessary to control certain loads from the centrally-located control panel using *main circuit switches*. For example, in a school, classroom lights may be switched ON from the charge controller located in the office. This prevents misuse of lights by students in the classrooms. In a home, the lights can be turned OFF from the main circuit switch during the day to prevent draining of the battery by lights accidentally left ON.

### Power Management

Charge controllers perform services that protect the system and notify the user as to whether the system is functioning properly.

Charge controllers often contain a *blocking diode*. Blocking diodes prevent current from flowing from the batteries to the solar cell module when the battery voltage is higher than the module voltage (see Figure 5.3). When the modules are not

producing current at night, the battery voltage is higher than that of the modules, and current will flow *backwards* to the modules. This loses energy in the system. A blocking diode is like a one-way gate that allows current to enter the battery from the module but does not allow it to flow back. Instead of using a blocking diode, some charge controllers automatically disconnect the solar modules from the battery when no current is flowing from the module. Blocking diodes may also be installed inside the junction box of the module by the solar electric agent.

Part of the work of charge controllers is to inform the user whether the system is properly working. Usually, light-emitting diodes (LEDs), beepers or alarms are used for such purposes:

- The *solar charge light* indicates whether a current is flowing from the solar array to the battery. It lights up when the array is charging the battery. If the solar charge light

does *not* come ON when the sun is out, the cause could be any of the following problems:

- a loose connection on the charge wire
- bad fuse or disconnected circuit breaker
- loose battery terminal
- bad battery or cell
- broken solar cell module

- The *low battery light* notifies the user that the battery is in a low state of charge. If this light comes ON, the user should completely stop, or reduce *as much as possible*, the use of electrical lights and appliances until the battery is in a higher state of charge. Some controllers use an alarm or beeper instead of an LED light. The low bat-

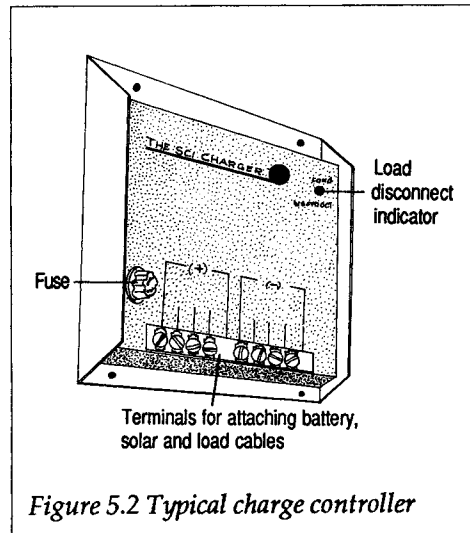
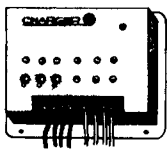

Figure 5.2 Typical charge controller

Blocking diodes prevent current draining from the batteries to the solar cell modules at night.



## Charge Controllers and Load Management

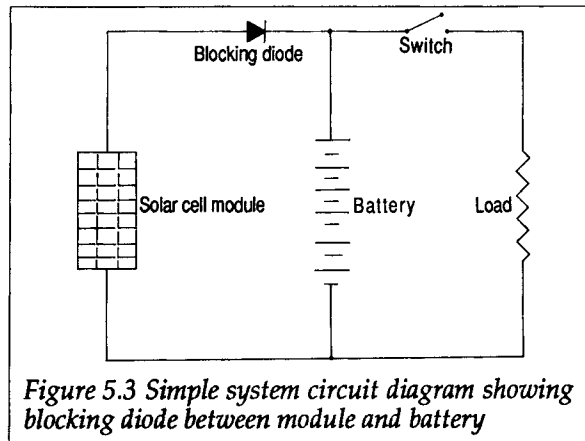

Figure 5.3 Simple system circuit diagram showing blocking diode between module and battery

tery light avoids the need to continually use a hydrometer to check the battery state of charge.

- The *battery full light* tells the user that the battery is fully charged, and, with some controllers, that the controller has reduced the battery charging current to a trickle charge.

Charge controllers often manage the system by automatically disconnecting the load or array from the battery.

- The *low battery disconnect* continuously measures the state of charge of the battery. If the state of charge drops to a level that is too low (for example, 40% SoC), the charge controller disconnects the load from the battery. This might happen during the cloudy season when the television is being used too much, and when there is not enough charge to bring the battery state of charge up. With some charge control-

lers, the level at which the controller cuts off the load can be adjusted.

- The *charge regulator* prevents the array from overcharging the battery. Like the low battery disconnect, it also monitors the battery's state of charge. When it gets above 90% SoC, the controller reduces the current from the module to a *trickle charge*, which is a very small current that fills the battery slowly without causing gassing. Such

a charge regulator is not required when the battery is properly matched to the solar cell module (i.e. a 40 Wp module attached to a 100 Ah battery does not normally require a charge regulator).

The controller may include other features to enhance the system's performance.

- *Load timers* are switches that connect and disconnect loads after a certain amount of time. They automatically turn loads ON, limit the amount of time that the loads are kept ON, and prevent abuse of the battery. For example, in a school, a load timer might switch classroom lights so that they come ON at sunset, stay ON for three hours before automatically being turned OFF.
- *Ammeters* and/or *voltmeters* measure the current and potential difference of the load, batteries and modules. On large systems, they are sometimes in-

Charge controllers often manage the system by automatically disconnecting the load or array from the battery.

Table 5.1: Comparison of Three 12 volt Charge Controllers

These three charge controllers are available on the market in East Africa (see Figures 5.2 and 5.4).

Feature	Sollatek SPCC 05	Sollatek SPCC 20	SCI Charger
<b>Installation Size</b>	up to 40 Wp	40 to 200 Wp	up to 200 Wp
<b>Voltages available</b>	12, 24, 48	12, 24, 48	12, 24
<b>Maximum current</b>	5 amps	20 amps	20 amps
<b>Blocking diode</b>	Yes	Yes	Relay disconnect
<b>Low Voltage Disconnect</b>	10.0 volts (adjustable)	10.0 V (adjustable)	11.0 V
<b>Reconnect voltage</b>	11.7 V	12.5 V	13.0 V
<b>Indicator lamps</b>	Green: load connected Red: Battery low, load disconnected	Green: Fully charged, module disconnected Yellow: Charge ON Red: Battery low, load disconnected	Red: Battery low, load disconnected

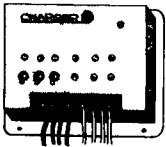

## Charge Controllers and Load Management

Load timers automatically turn loads ON, limit the amount of time that the loads are kept ON, and prevent abuse of the battery.

stalled in the control panel to allow users to monitor their system's performance. If a voltmeter is installed in the controller, the battery voltage (and hence state of charge) can be checked by looking at the control panel. Similarly, output of the solar modules and the current of the load can be carefully monitored by users.

- *Surge protectors* protect the system components and appliances against the rapid power increases expected when lightning strikes nearby. A module (and the other solar equipment) will probably not survive a direct lightning strike but, if lightning strikes nearby, a surge protector would prevent damage to the system. Surge protectors operate by disconnecting

the system when a very high current moves through the wire.

## Choosing Charge Controllers

Charge controllers are rated according to the current they can manage. The smallest available controllers are rated at 5 amps; they best serve systems with a few lamps and a radio. A home with a television, four or five lamps, a cassette player and a sewing machine would require a 20 amp controller. As of 1991, not many charge controllers were available separately in East Africa, but it is hoped that as the industry develops more will become available at lower prices. Table 5.1 compares some of the charge controllers that are available on the local market.

Figure 5.4: The Sollatec SPCC 20 Charge Controller

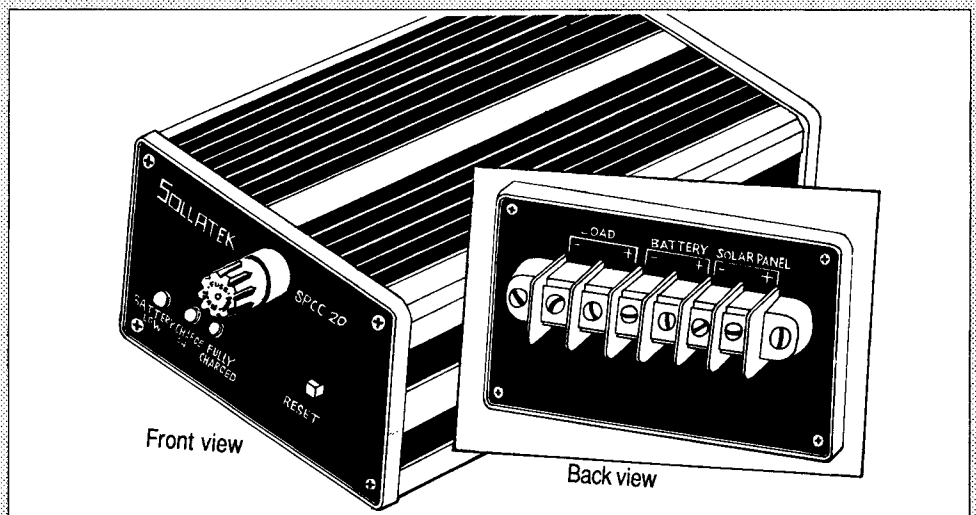

The Sollatec SPCC 20 is an example of a locally-available charge controller. It contains a 20 amp fuse, and is suitable for larger 12 volt home lighting systems (i.e. five or more lights with a television). The controller features a *low voltage lamp* and a *low voltage disconnect* (this is set at 10 volts, which is extremely low, but the manufacturer claims it can be set higher; i.e. 11 volts). When the battery reaches a low state of charge (10 volts), the load is automatically disconnected and a red LED warning lamp comes on. Once the battery has been disconnected, users cannot turn ON lights or television until the battery has reached a higher state of charge and the controller has been reset.

The controller has a green *battery full* indicator lamp which turns ON when the battery is fully charged. When this lamp comes ON,

the charge from the module to the battery is disconnected by a *charge regulator*. There is also a *solar charge lamp* which turns ON when batteries are being charged by the solar modules. If the low voltage disconnect turns OFF the load, then the user must wait until the batteries have been charged up again. After some charging, press the *reset button*. If the state of charge and voltage has gone up sufficiently, the load will be re-connected.

The diagram shows where the cables to the battery, module and load are connected on the back of the controller. Note that the positive and negative terminals are clearly marked. When installing and connecting the controller, the positive and negative leads *must* be connected to the correct terminal (see Chapter 11).

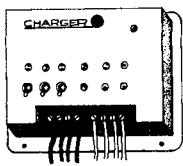

## Charge Controllers and Load Management

### Local Production of Charge Controllers

Charge controllers are manufactured from various electrical components (i.e. relays, diodes, resistors and circuit boards). Most charge controllers used in East Africa today are imported. However, they can be assembled from locally-available components. By 1990, at least one East African company had begun assembling charge controllers. Cottage industries in Kenya have successfully designed, assembled and sold their own controllers.

If you chose not to use a charge controller, take special care to manage the energy so that the battery is not ruined.

Figure 5.5 shows a circuit diagram which can be used to build a very simple charge controller with locally available electrical spares. The controller has an LED solar charge indicator lamp, a fuse and switches for the sockets and lights. It does not have

must take special care to manage the energy so that the battery is not ruined.

At times there is not enough solar power to fully recharge the batteries, especially in the case of 20 Wp or smaller systems. Take, for example, the cases of Meru, Kenya, Arusha, Tanzania or Mbarara, Uganda which have less than 4.5 peak hours of insolation per day during certain months. As the cloudy days go by, users in such places are likely to take more energy out of the battery each night than was put in by the solar charge, while the battery steadily loses its charge. Within two weeks, the battery may be completely discharged and permanently damaged.

The guidelines below suggest ways by which a system can be effectively managed without a controller. Chapter 10 discusses further techniques of effective energy management (see page 75).

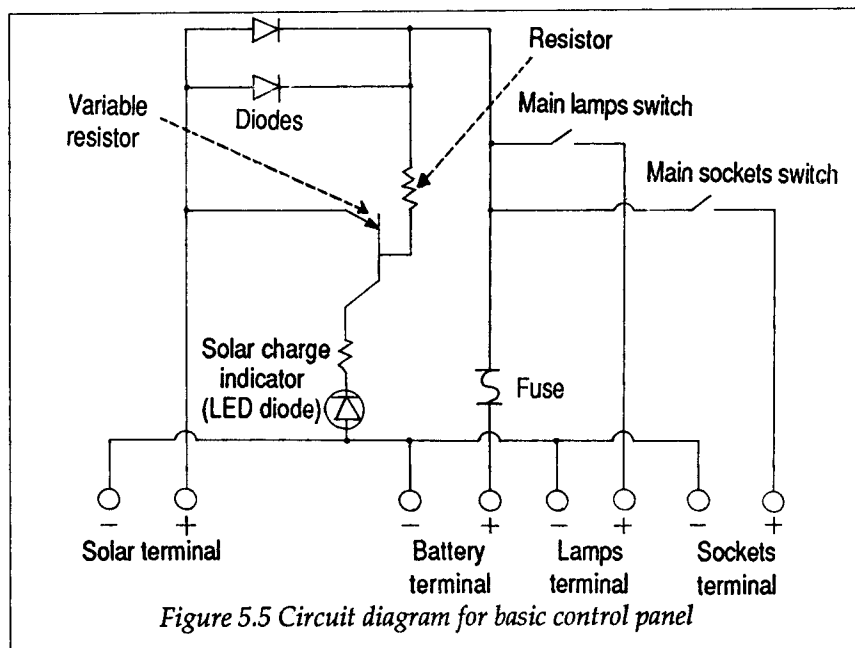

a low voltage warning light or disconnect, however, so the user would still have to manage the energy flow of the system.

### Managing Systems without Controllers

Because of the high cost of charge controllers, many small system buyers choose not to install one in their system. Without a controller, however, the battery is not protected by a low voltage disconnect from deep discharging. In such cases, the user

screen, and the motors in cassette players and other machines run slowly.

- Calculate the approximate energy harvest of the module (see page 23), and adjust energy use so that it is approximately the same as energy harvest.
- When the battery state of charge is low, limit the use of appliances.
- Charge the battery by other means if necessary (see page 33).