

including  
**CATALOGUE**  
of locally manufactured tools

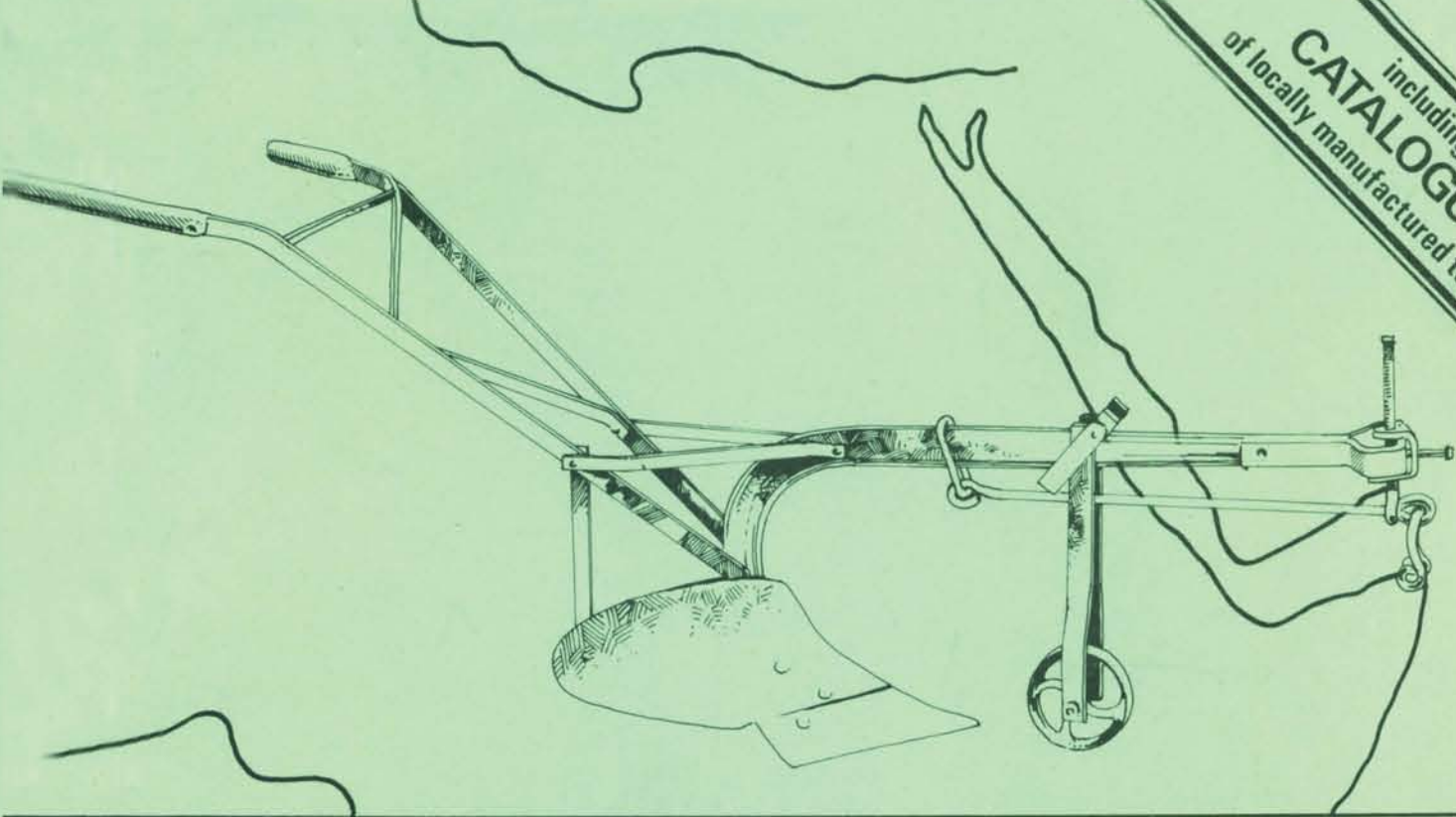

# GUIDE TO TECHNOLOGY TRANSFER

in East, Central and Southern Africa

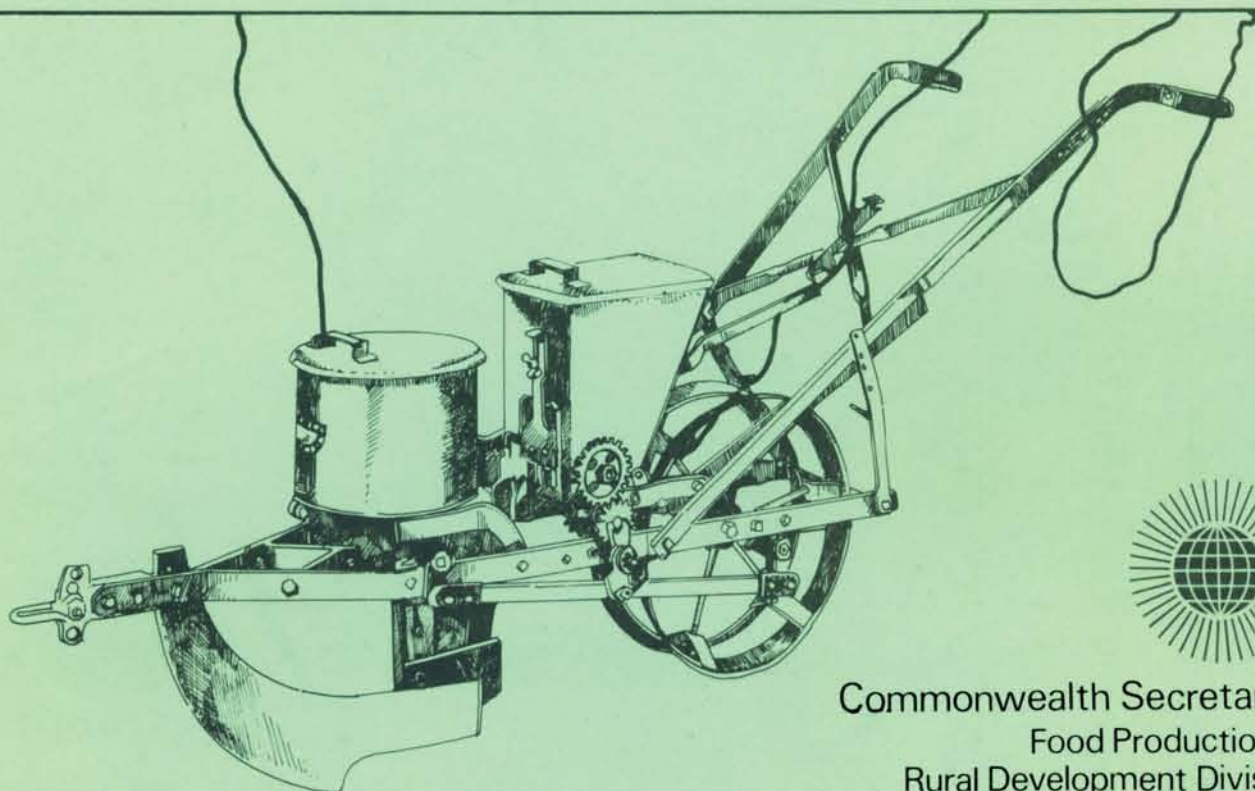

Commonwealth Secretariat  
Food Production &  
Rural Development Division

# Guide to Technology Transfer in East, Central & Southern Africa

---

A CATALOGUE OF AGRICULTURAL EQUIPMENT  
MANUFACTURED IN THE REGION, WITH A GUIDE  
TO ITS PURCHASE AND USE

---

Compiled by Anthony Ellman  
Bruce Mackay  
Tony Moody

Drawings by Andrew Crane

Food Production & Rural Development Division  
Commonwealth Secretariat  
Marlborough House  
Pall Mall  
London SW1Y 5HX

March 1981

© Copyright 1981

Printed and published by  
The Commonwealth Secretariat

May be purchased from  
Commonwealth Secretariat Publications  
Marlborough House  
London SW1Y 5HX

ISBN 0 85092 198 8

## CONTENTS

	<u>PAGE</u>
1. Background To The Guide	5
2. Agricultural Technology In East, Central & Southern Africa - Use of The Guide To Technology Transfer.	7
3. Catalogue of Implements:	
Ploughs, Ridgers & Cultivators .....	15
Hand Tools .....	25
Toolbars & Tractors .....	29
Harrows .....	37
Seeders .....	41
Harvesters .....	47
Threshing, Winnowing, Cracking & Shelling ....	49
Grinding Mills .....	57
Crop Storage .....	63
Pumping .....	63
Power .....	75
Incubator, Honey & Mohair .....	79
Transport .....	85
4. Country Guides:	
Botswana .....	89
Kenya .....	93
Lesotho .....	99
Malawi .....	103
Swaziland .....	107
Tanzania .....	111
Uganda .....	117
Zambia .....	121
Zimbabwe .....	125
5. Indexes:	
Index of Manufacturers .....	129
Index of Tools and Implements .....	132

## ACKNOWLEDGEMENTS

Preparation of this guide has been a joint effort, and has only been possible with the informative and prompt help of a large number of manufacturers in Africa, and a large number of helpful officials in each country that is covered.

Antony Ellman and Tony Moody of the Food Production and Rural Development Division prepared the outline of the guide, acted as editors and wrote the introductory chapters. Visiting the region several times between 1977 and 1980, they located manufacturers and agents and collected basic information for the guide. Tony Moody wrote the text of the catalogue.

Dr. Bruce Mackay, Consultant to the Division, continued the information search, contacting manufacturers, and receiving detailed and helpful replies. He also wrote the text of the country guides, collecting information from various sources including the Department of Trade in London who supplied information about trade regulations and customs tariffs.

Andrew Crane prepared the line drawings of the implements described, using a wide range of reference material, from photographs to scale drawings, highlighting the individuality of each design.

Doris Ng and Georgina Wilson typed the manuscript and Geoff Turner and Bob Poulson of the Printing Section gave valuable assistance with lay-out and art-work.

LONDON, MARCH 1981

## 1. BACKGROUND TO THE GUIDE

---

The origin of this Guide to Technology Transfer can be traced to the Rural Technology Meeting organized by the Commonwealth Secretariat with the Government of Tanzania in Arusha, Tanzania in August 1977. At that meeting more than 100 items of locally made equipment from all countries of East, Central and Southern Africa, as well as some from West Africa, India and Papua New Guinea, were brought together and tested in the field by participants drawn from all the countries of Commonwealth Africa. The participants also had the opportunity to compare experiences of tackling the technical, economic and administrative problems of getting appropriate equipment from the drawing board to the factory bench, and thence out to the users.

The Arusha Meeting was effective in opening people's eyes to the wide range of implements designed and made in the countries of the region. Though most countries still depend heavily on imported agricultural equipment from the developed world, the meeting showed that many of these imports are high cost, inappropriate to countries' needs, difficult to maintain in remote rural areas, and that they could to a large extent be replaced by locally manufactured alternatives.

Following the meeting there has been some expansion of technology transfer within the region. Countries were able to obtain samples of the items they saw at Arusha which they thought appropriate to their needs. Local manufacture of simple tools - for example ox-ploughs, harrows, tool bars and water pumps - has expanded in some countries. Plans have been drawn up in other countries for local manufacture under licence of more complex items such as small tractors. Exchange visits have been arranged to promote further the spread of information between countries.

But the barriers to communication and technology transfer are still very strong. Even when countries know the equipment they want, and have found out where it is made within the region, logistical obstacles, customs barriers and financial restrictions often prevent them from obtaining it. It is frequently easier to purchase from established suppliers through established trade routes in Europe, than from a manufacturer just over the border in a neighbouring territory.

This Guide has been prepared to help to break down such barriers. Its publication has been delayed to await the achievement of independence in Zimbabwe, which is not only an important manufacturer of agricultural equipment in its own right, but also forms an important link in the trade routes between East and Central Africa on the one hand, and Central and Southern Africa on the other.

In East Africa the demise of the East African Community has left countries cautious about unequal exchanges with their neighbours, but no less conscious of the need for developing mutually beneficial trading relationships within the region. In Central and Southern Africa the establishment of the Southern Africa Development Co-ordination Conference, emerging from the grouping of Front Line States forged in the Zimbabwe Liberation War, has the objective of reducing economic dependence on South Africa and strengthening economic integration between the member countries. The authors of this Guide therefore expect that the information it contains will fall on fertile ground; they trust that it will prove useful both to manufacturers and to users of agricultural equipment in East, Central and Southern Africa.

Comments on any part of the publication, including its usefulness, shortcomings and suggestions for improvement, would be welcomed and should be sent to:

The Director  
Food Production & Rural Development Division  
Commonwealth Secretariat  
Marlborough House  
Pall Mall  
LONDON  
SW1Y 5HX

## 2. AGRICULTURAL TECHNOLOGY IN EAST, CENTRAL AND SOUTHERN AFRICA

---

**Introduction** Historically, poor communications and imperfect markets have obstructed the free transfer of appropriate agricultural technologies in sub-Saharan Africa. Traditional hand tools, of which in the 19th century there was a wide range well suited to local conditions, disappeared in most parts of the continent as mass produced alternatives were imported from the West. But few of the imported tools were designed for African conditions, and most have proved physically, ecologically or economically inappropriate. Only in recent years have serious attempts been made to produce in Africa tools designed specifically for local conditions, building on both imported and indigenous experience. However, few of these tools have yet become widely available.

In Eastern Africa during the colonial period local manufacture of handtools by village blacksmiths was discouraged in order to secure a colonial market for the limited, and now familiar range of hoes, forks and cutlasses made and designed in Europe. Traditional designs of handtools survive in West Africa: in East and Central Africa they are a lost technology. In order to accelerate the output of industrial crops, the colonial powers then introduced animal-drawn agricultural tools, and this was accompanied by the spread northwards of designs brought to Africa by the Boer settlers of South Africa. Hence most animal-drawn implements used in ECS Africa (1) today are derived from European models, dominated by the single furrow mould-board plough.

In the immediate post-independence period of the 1960s there was a widespread introduction of tractors to ECS Africa, to raise the productivity of agriculture, and a similarly extensive adoption of diesel powered water-lifting, generating and milling machinery. During this time, the use of animal-drawn tools also increased, but their design was seldom questioned and most were imported from established European and South African sources.

---

(1) ECS Africa is used throughout to refer to East, Central and Southern Africa, the region with which this guide is concerned. The countries included, from north to south, are Kenya, Uganda, Tanzania, Malawi, Zambia, Zimbabwe, Botswana, Swaziland and Lesotho. The guide should also be of use to Mozambique and Angola, members of the newly formed grouping of Southern African States.

Finding the  
Appropriate  
Design

Many of the low-cost implements suitable for agriculture in ECS Africa can now be found within the region, and are simple enough for local manufacture. Imported models can be made more appropriate by adaptive research and development, and indeed agricultural research centres in ECS Africa have paid increasing attention to the design or development of new tools which are particularly appropriate to local conditions.

Attention has to be paid not only to engineering aspects, but also to the availability of animal and other forms of power, to the peak periods of labour demand in peasant agriculture, and to the maintenance skills found in rural areas. Increasingly such research is done in collaboration with research centres in other countries of the region, which greatly reduces its cost and increases its effectiveness.

Moving to  
Local  
Manufacture

The surest way in which countries can obtain agricultural equipment appropriate to their needs is to make it themselves. There has indeed been a considerable expansion of local manufacture of agricultural implements in the region in recent years.

In the 1960s there were less than ten factories in ECS Africa manufacturing a restricted range of agricultural implements: today, as this catalogue shows, there is a wide range of tools produced in some thirty factories spread through every country of the region, and these are all tools appropriate to low-cost, small farm operation.

Initially the designs used were derivatives of the models previously imported: seven local factories now manufacture single-furrow mould-board ploughs based on the original South African designs. But some smaller workshops are now producing more original designs, based on local research and better suited to local conditions. Manufacturing in the region is thus at a transitional stage between the use of imported and locally developed designs.

Constraints  
to Local  
Manufacture:  
Patents

Local manufacture or assembly of imported designs of complex equipment is generally arranged under licence or in agreement with the original producers. But with simpler low-cost agricultural tools, 'pirating' - manufacture in defiance of, or in the absence of, design patents - is much more commonly practised.

Although pirating is the simplest way of gaining access to a design, it frequently leads to an unsatisfactory end-product, the copy being markedly inferior to the design it copies. The lack of co-operation between the 'pirate' and the original manufacturer usually results in ignorance of important information on specifications and manufacturing technique.

In fact pirating in this context is generally unnecessary. While it attempts to side-step apparently expensive licensing arrangements, such arrangements may not prove to be expensive at all when applied to low-cost designs of agricultural equipment. For defensible patents for such agricultural implements are generally either technically impossible to secure, or their cost is out of all proportion to the value of the implement. It is also difficult for the manufacturers to prove that their design is in fact original. Thus few designs of agricultural implements are truly patentable.

From recent experience in the region, the development of quite open exchange agreements is recommended. If there is any cost in such an agreement it should be more than adequately covered by the insurance that the copy will perform as well as the original. Furthermore, with the transitional stage in manufacturing existing in most countries of the region, it is also likely that the exchange of designs will bring valuable feedback to the original designer, from modifications and observations made on use of the implements in a different environment by a different group of specialised users and testers(2).

Technical &  
Economic  
Constraints  
To Local  
Manufacture

Of the several constraints to local manufacture, two are worthy of mention here: one is technical, the other is economic. A major technical constraint is the need for high quality materials in some important components. Cultivation equipment (handtools and ox-ploughs alike) needs high quality steel for soil-contacting parts, and local steel mills cannot yet fully meet this demand. Milling and pumping equipment needs durable sealed bearings, for which demand in the region is still insufficient to justify local manufacture. Thus some components still have to be imported, and this affects the potential for manufacture of otherwise good local designs, since manufacturers of the imported components are unlikely to be able to produce parts to the exact specifications of a factory in the region.

A major economic constraint is the size of the market. Within the region as a whole, and even within different countries, the market for agricultural implements may not be smaller than that served by some successful European manufacturers. With local manufacture leading to greater specialization of designs - for different crops, different soil types, different resources of animal power - the market that an individual factory can penetrate without assistance could be too small to justify mass manufacture.

There is, therefore, a pressing need for assistance and initial protection of local industries, though the risk of subsidising inefficiency and of inhibiting regional specialization must be guarded against. At the same time there is a need to increase the size of the market, both internally and through export leading to regional trade. As an indication that this can be done, the catalogue includes the products of a West African factory which has already embarked on large-scale manufacture of tools designed specifically for West African markets and appropriate also for many countries of ECS Africa.

- 
- (2) Further information on patents and trademarks, and their use and abuse in technology transfer, can be obtained from the:

East & Southern African Intellectual Property  
Organization,  
World Intellectual Property Organization,  
United Nations,  
Palais des Nations,  
GENEVA,  
Switzerland

Regional  
Trade in  
Agricultural  
Equipment

Awareness of the potential benefits of regional trade in this part of Africa is not new. In the colonial and the immediate post-colonial period two regional groupings functioned: the Central African Federation and the East African Community. These groupings each gave markets of three countries to factories in one of the countries. They also used a road and rail infrastructure that linked the countries effectively and played a big part in serving the regional markets.

The countries did, however, have common currencies and, initially, common political control. As independent economic and political control developed in each country, so the groupings collapsed. In each case one country came to dominate the group economically, and the other countries suffered from the inequality. Today there is only one established regional trading agreement in ECS Africa, the South African Customs Union, but that is dominated by the dependence of three land-locked countries - Botswana, Lesotho and Swaziland - on South Africa.

The countries of the region, with the exception of Lesotho, all share land borders one with the other. Across these borders, linking Uganda in the north with Botswana in the south, there is a network of roads and railways that could carry a substantial volume of regional trade. However, at the present time this transport network is still used overwhelmingly for the import and export trade of individual countries with the world beyond the region. Even in agricultural equipment, each country's major trading partners are outside the region.

The existing constraints on regional trade are logistical, financial and political. Publication of this guide may directly contribute only to the solution of one of the logistical constraints - poor market intelligence. Although most countries of the region have a common language and common borders, the extent of product knowledge between them is quite imperfect. Hopefully the catalogue will improve this knowledge. The country guides may also give some guidance to manufacturers, concerning other countries of the region in which there might be a market for their products.

Indirectly, however, it is hoped that the guide will indicate the potential benefits to be gained from resolving the more critical obstacles to regional trade. Communication between buyer and seller is still very difficult. At least two telecommunications systems operate in the region, co-ordination between them relying on relay with Europe. Air-mail facilities are still dominated by a north-south pattern between each country and Europe. Although the transport infrastructure exists, the co-ordinated use of it for regional trade still relies on a handful of private agents whose main business is import and export between the country in which they operate and the outside world (3).

- 
- (3) Some agents have branches in a number of countries: these are listed in the country guides.

The financial constraints are crucial. In the absence of special agreements trade between countries of the region is still financed by using third-country currencies. Hence the willingness to participate in regional trade is still as severely conditioned by foreign exchange reserves as is trade with countries outside the region. Associated with this, the financial institutions that could be used to co-ordinate regional trade are dominated by their links with metropolitan Europe; their regional links are secondary. Thus there are few special regional credit facilities operating, for example, between branches of the major trading banks in one country of the region and another.

There are also political constraints. The border between Kenya and Tanzania remains closed, making trade between Kenya and the rest of the region dependent on expensive trans-shipment by sea. In effect, also, trade between East and Southern Africa is politically constrained by the land-lockedness of Botswana, Lesotho and Swaziland in relation to South Africa.

The influence of South Africa, combined with the achievement of independence at last in Zimbabwe has, however, led to the institution of a new regional agreement that should resolve many of these constraints on regional trade. Heads of State of nine Southern African countries, meeting in Lusaka, made a historic Declaration on Development Co-operation on the 1st of April 1980 - the 'Lusaka Declaration'. This was a declaration by Angola, Botswana, Lesotho, Malawi, Mozambique, Swaziland, Tanzania, Zambia and Zimbabwe of 'a strategy for a closer integration of their economies ..... so as to accelerate their development and reduce their dependence on the Republic of South Africa.'

These nine countries are now linked through the Southern Africa Development Co-ordination Conference, whose programme of action will include the creation of a Regional Transport and Communications Commission, and plans for the harmonization of industrialization and energy policies leading ultimately to a great expansion in local manufacture of industrial products and regional trade.

PART 3 : THE CATALOGUE

**Geographical Coverage** With one exception, all the implements shown are made and/or designed in the Commonwealth countries of ECS Africa: Botswana, Kenya, Lesotho, Malawi, Swaziland, Tanzania, Zambia and Zimbabwe. The one exception is the range of products from the Siscoma factory in Senegal. This factory is unique in Africa for its mass-production of implements designed specifically for African conditions. Its products have been included because we consider information about them can fill important gaps in the demand for tools in ECS Africa.

**Range of Implements Included** It is not easy to define objectively the range of equipment that classes as being useful for agricultural development. On the one hand a strict limitation to agricultural tools would be too narrow; on the other hand inclusion of all equipment used in rural areas would make compilation of the Guide unwieldy.

The range of equipment covered by this catalogue includes: implements for cultivation, harrowing, weeding, planting, harvesting, winnowing, threshing, milling and storage of crops, and irrigation, power, transport, poultry, spinning and beekeeping equipment. Tractors over 30HP, and all tractor-drawn implements have been omitted, as this is a catalogue of small-scale machinery. Other categories of equipment may be included in a later edition if there is sufficient demand.

We hope that we have uncovered, in the course of our research, all relevant implements that are being developed and manufactured in Commonwealth East, Central and Southern Africa. Undoubtedly some have been omitted: that is inevitable with this kind of research. Therefore we rely heavily on the publication of the catalogue, its dissemination, and the reaction of readers to help us perfect the coverage for a subsequent edition.

Furthermore, designs proceed from the laboratory stage through field testing, modification and prototype production, to limited and ultimately large scale manufacture. We have endeavoured to draw a line between those designs in the developmental stage and those that can be or are being manufactured. We have not limited coverage purely to commercial factories. Some factories only produce to order, and some research establishments are able to engage in limited manufacture. We have therefore included both these groups, while excluding designs that, to our knowledge, are still at the prototype stage.

**Availability of Equipment** The main constraint on availability, especially of items manufactured in another country, is market facilities. Even where these exist, it may be found that some items are not available for export because the manufacturer is working at full capacity to fulfil local orders.

Direct communication with the manufacturer is essential in this regard. To facilitate this the full postal address, telephone and telex numbers of manufacturers have been included wherever possible.

Descriptions & Illustrations As far as possible individual drawings and descriptions of each implement have been included, even where some designs are remarkably similar. We have tried to focus, therefore, on distinguishing features between designs, however slight.

Prices Some reference to price has to be made in a catalogue, to enable users to make an estimate of the initial cost of obtaining an implement. The up-to-date price for all implements for the nearest date to 1st May 1980 has been obtained, and in each case the relevant date is quoted. Prices are given in local currency and US\$ equivalents at 1st May 1980 exchange rates. Prices change constantly and the prices quoted should not be taken as the basis for any contract. They were supplied by manufacturers on this understanding. ACTUAL PRICES MUST BE VERIFIED FROM THE MANUFACTURER.

#### PART 4 : THE COUNTRY GUIDES

A short guide to each country has been prepared and these are included in alphabetical order: Botswana, Kenya, Lesotho, Malawi, Swaziland, Tanzania, Uganda, Zambia and Zimbabwe.

Each country guide consists of the following sections:

Agriculture A brief summary is included which indicates the main features of land types, distribution of land-holding, and principal crops grown. Though the information is not complete in every case, it should show the types of equipment which may be in greatest demand, and the approximate size of potential market.

Technology The relative importance of hand-labour, animal power and mechanical power is shown, and an indication is given of government policy towards agricultural mechanization.

Mention is also made of national institutions responsible for the promotion of agricultural technology, and a brief summary is given of the type of industry engaged in the manufacture of agricultural tools and implements.

Freight Agents & Transport Companies We have listed the principal agents and transporters in each country. Identification of a competent agent is generally a prerequisite to the successful fulfilment of an order or delivery. Importers or exporters contemplating the use of one of the named agents in their own country, should show the list of agents in the country they intend dealing with to that agent. Agents usually have special working relationships with counterparts in other countries.

Agents should also be aware of customs and trade regulations that may not be included in this guide.

Trade  
Regulations &  
Customs  
Tariffs

These are included as much for the guidance of importers as for exporters. Customs tariffs quoted are for agricultural implements only, and all information given here should be checked for accuracy with:

- (a) Departments of Customs and Excise
- (b) High Commissions, Embassies and Trade Commissions
- (c) Departments of Trade in Ministries of Commerce and Ministries of Finance.

With this information, the guides can be used by manufacturers to assess the potential market for their products in neighbouring countries and to assess the facilities available for reaching these markets. The guide should also be of use to those wishing to order machinery from other countries, by providing them with information on the import regulations and availability of transport facilities.

We are fully aware that the country guides could include more detailed information, which would be of value to manufacturer and user alike. It would have been satisfying to have been able to prepare a more thorough analysis of markets and to have included more information about the actual costs of using various transport alternatives. However that would have demanded more time and resources than were available. It is our hope that this publication may encourage organizations within the region to attempt to fill these gaps in the future.

3 : CATALOGUE OF IMPLEMENTS

# PLOUGHS, RIDGERS, CULTIVATORS

## PAP DRAGON OX PLOUGH

### Manufactured by:

Ploughs & Allied Products Ltd  
PO Box 467  
KISUMU  
Kenya

Telephone: Kisumu 40512

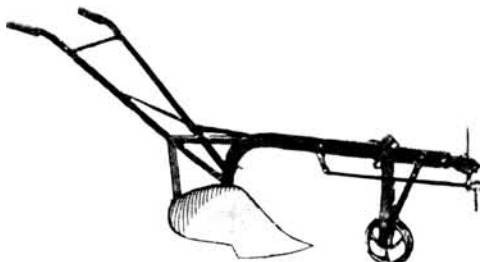

Description: The PAP Dragon is a standard design of mouldboard plough whose basic features are a curved beam, a mouldboard plough-share, a wheel and handles. The beams are of high-carbon steel and are imported, as are the cast-iron wheels. The other parts of the plough are made at the factory from steel sections, and as all the dimensions are standard with other similar designs, replacement of parts is relatively easy. Ploughs & Allied Products report annual sales in excess of 3000 units per annum.

Price: (ex-works) (as at 1.7.80) Kshg.365.00 (\$49.00)

## 'LION' OX PLOUGH

### Manufactured by:

Ideal Casements (E.A.) Ltd  
PO Box 45319  
NAIROBI  
Kenya

Telephone: Nairobi 555599/555319

Telegrams: IDEASMENT



Description: The Lion ox-plough is a standard design of mouldboard plough similar to models manufactured elsewhere in Africa. Ideal Casements manufacture all the components locally in Kenya, including the plough-shares made from heat-treated steel. Ideal Casements have been manufacturing the plough for 14 years and produce over 7000 units per year.

Price: (retail) (as at 1.4.80) Kshg.300.00 (\$40.00)

---

(PRICES LATEST AVAILABLE FOR GUIDANCE ONLY. REFER MANUFACTURER FOR ACTUAL)

## N'GOMBE OX-PLOUGH

### Manufactured by:

Ubungo Farm Implements Ltd (UFI)  
PO Box 20126  
DAR es SALAAM  
Tanzania

Telephone: Dar 53146-8

Telex: 41206 Dar es Salaam

Telegrams: MAJEMBE

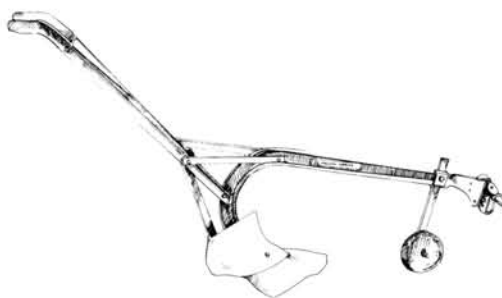

Description: The N'gombe ox-plough is a single furrow mould-board plough of standard design. It is of all steel fabrication and the share is of heat-treated steel. The weight is 31 kgs.

Price: (retail) (as at 1.1.80) Tshg.404.00 (\$50.00)

## SINGLE-FURROW PLOUGH

### Manufactured by:

Agrimal (Malawi) Ltd  
PO Box 143  
BLANTYRE  
Malawi

Telephone: Blantyre 30692, 31259

Telex: 4282 MI

Telegrams: AGRIMAL



Description: A single-furrow mouldboard plough of conventional design with a share made from heat-treated steel. Agrimal currently manufacture 15000 per annum. The plough is available in 20 cm. and 25 cm. models.

Price: (ex-works) (as at 1.2.80)

20cm.	-	57.35 kwacha	(\$70.00)
25cm.	-	57.90 kwacha	(\$71.00)

---

(PRICES LATEST AVAILABLE FOR GUIDANCE ONLY. REFER MANUFACTURER FOR ACTUAL)

## 'HUARD' MOULDBOARD PLOUGH

### Manufactured by:

SISCOMA (Factory  
BP 3214 at Pout)  
DAKAR  
Senegal

Telephone: Pout 81096, 81136

Telex: 7781 SISCOMA SG

City Office: SISCOMA  
rue du Dr Theze/  
Grammont  
DAKAR  
Senegal

Telephone: 22375-84



Description: The Huard mouldboard plough is similar in design to those produced in Anglophone countries and similarly has an adjustable and replaceable share. The traction linkage is however different and allows a greater degree of adjustment for different heights of harness to obtain the most efficient angle of penetration.

Price: (ex-works) (as at 1.1.80) 25,673 CFA (\$120.00)

## OX-PLOUGH

### Manufactured by:

Agricultural Implements  
Manufacturers  
PO Box 1553  
NAKURU  
Kenya

Telephone: Nakuru 41672

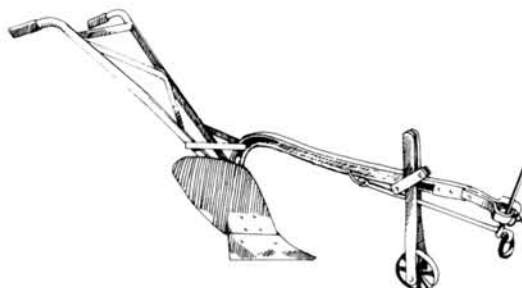

Description: A mouldboard plough, with adjustable and replaceable share of standard design. The plough is manufactured in 3 sizes.

Price: (ex-works) (as at 1.1.80)

1. Small	Kshg.390.00	(\$52.20)
2. Medium	Kshg.450.00	(\$60.25)
3. Large	Kshg.550.00	(\$73.60)

---

(PRICES LATEST AVAILABLE FOR GUIDANCE ONLY. REFER MANUFACTURER FOR ACTUAL)

SILVER MEDAL OX-PLOUGH

Manufactured by:

Bulawayo Steel Products  
8 Ironbridge Road  
Donnington  
PO Box 1603  
BULAWAYO  
Zimbabwe

Telephone: Bulawayo 62671/2

Telegrams: BYOSTEEL

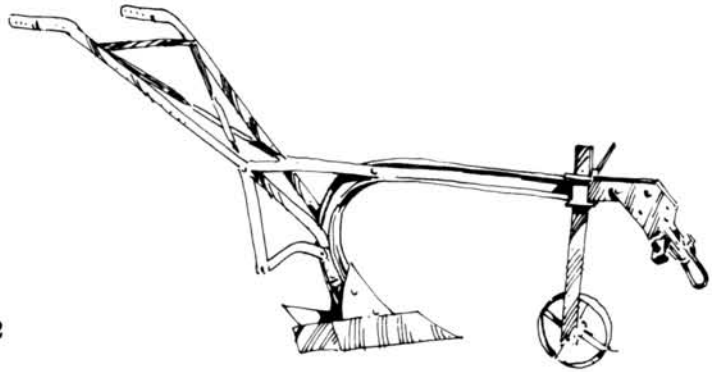

Description: The standard ox-plough design has been modified to eliminate the need for spanners to adjust the blade and handle setting. The wheel adjustment and linkage have also been modified, and the frog has been strengthened. The Institute of Agricultural Engineering in Salisbury have designed alternative attachments which can be fitted in place of the mould-board. These are:

- (a) a single tine for reduced tillage;
- (b) a ridger blade; and
- (c) a groundnut-lifting blade.



Prices: (ex-works) (as at 1.7.80)

With 200mm flat share	Zim\$37.00	(\$57.00)
" 250mm " "	Zim\$37.30	(\$57.40)
" 300mm " "	Zim\$45.08	(\$69.35)

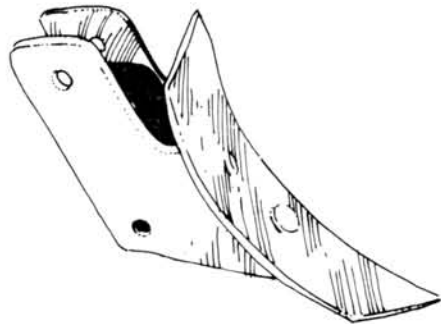

OX-PLOUGH

Manufactured by:

Northland Engineering Ltd  
PO Box 1640  
NDOLA  
Zambia

Telephone: Ndola 3712

Telegrams: Northland

Description: A standard design of ox-plough, manufactured throughout of mild steel. The beam is also of mild steel, for strength, and is of rectangular, rather than girder, section.

Price: (wholesale) (as at 1.7.80) 48 kwacha (\$61.00)

---

(PRICES LATEST AVAILABLE FOR GUIDANCE ONLY. REFER MANUFACTURER FOR ACTUAL)

## KIFARU PLOUGH

### Manufactured by:

Tanzania Agricultural Machinery  
Testing Unit (TAMTU)  
PO Box 1389  
ARUSHA  
Tanzania

Telephone: Arusha 3666

Telegrams: TAMTU

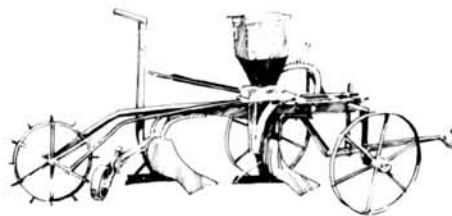

Description: The Kifaru is a heavy duty, double-furrow mouldboard plough, manufactured from locally available steel components. The frame is mounted on 3 wheels, 2 forward and one rear.

As cultivation with the Kifaru is usually carried out twice prior to planting, the Kifaru can be fitted with a metered seeding unit, for planting during the second cultivation pass. The whole seeding unit includes a metering wheel which trails.

### Prices: (ex-works) (as at 1.7.80)

Kifaru plough	Tshg.1500.00	(\$185.00)
Seeding attachment (see below)	Tshg. 600.00	(\$ 74.00)

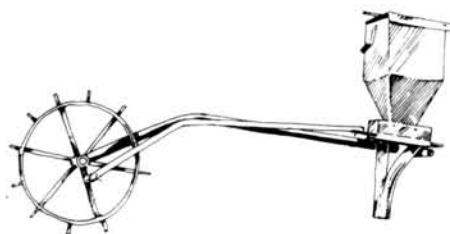

---

(PRICES LATEST AVAILABLE FOR GUIDANCE ONLY. REFER MANUFACTURER FOR ACTUAL)

TWO-FURROW PLOUGH

Manufactured by:

Rhoplw Ltd  
PO Box 1059  
BULAWAYO  
Zimbabwe

Telephone: Bulawayo 71363

Telex: RH3372

Telegrams: RHOPLOW

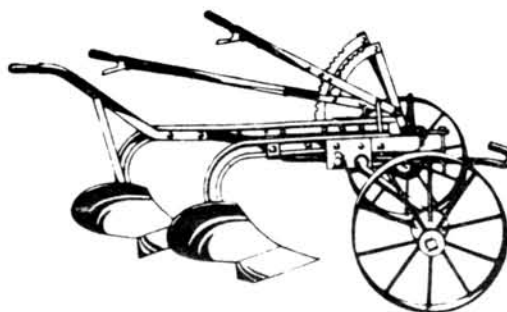

Description: The two beams are mounted on an axle between 2 widely spread metal-rimmed wheels. One beam is shorter, which presents the two shares in an off-set pattern to the land. The hand-levers are used to adjust the angle of the shares.

Price: (wholesale) (as at 14.4.80)

Zim\$185.80 (\$286.00)

SINGLE FURROW PLOUGH

Manufactured by:

Rhoplw Ltd  
PO Box 1059  
BULAWAYO  
Zimbabwe

Telephone: Bulawayo 71363

Telex: RH3372

Telegrams: RHOPLOW



Description: A standard design light-weight mouldboard plough, weighing 38 kg.

Price: (wholesale) (as at 14.4.80)

Zim\$36.50 (\$56.00)

---

(PRICES LATEST AVAILABLE FOR GUIDANCE ONLY. REFER MANUFACTURER FOR ACTUAL)

## AGRICO UNIVERSAL CULTIVATOR

### Manufactured by:

Ploughs & Allied Products Ltd  
PO Box 467  
KISUMU  
Kenya

Telephone: Kisumu 40512

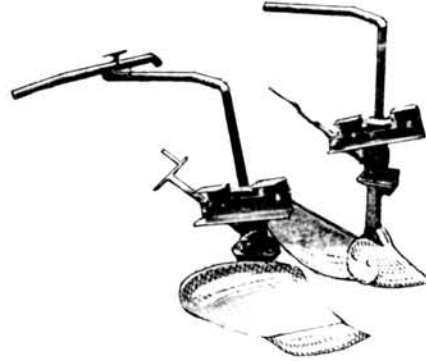

Description: The Agrico is produced and marketed as a light-weight (25kg.) cultivating share mounted to a handle, on which there is a bracket for attachment to beams and harnesses that are already available. Thus it can be fitted to tool-bar frames (e.g. the Sine tool-bar) or more simply to a wooden beam, on which there would be a forward skid. Only the high-carbon plough-share is imported, and annual production of the Agrico is presently around 100 units.

Price: (ex-works) (as at 1.1.80) Kshg.450.00 (\$60.00)

## STANDARD CULTIVATOR S51

### Manufactured by:

Agrimal (Malawi) Ltd  
PO Box 143  
BLANTYRE  
Malawi

Telephone: BLAntyre 30692, 31259

Telex: 4282 MI

Telegrams: AGRIMAL



Description: The Standard Cultivator is an all-purpose cultivator which is designed to weed between rows of varying widths - from 60 cm. to 100 cm. It is equipped with 3 different types of tine; 2 reversible shares in the front, 2 mouldboard hillers in the centre and a 25 cm. sweep in the rear, with 2 spare shovels.

Price: (ex-works) (as at 1.2.80) 77.15 kwacha (\$94.00)

---

(PRICES LATEST AVAILABLE FOR GUIDANCE ONLY. REFER MANUFACTURER FOR ACTUAL)

## 5 TINE CULTIVATOR MC5

### Manufactured by:

Agrimal (Malawi) Ltd  
PO Box 143  
BLANTYRE  
Malawi

Telephone: Blantyre 30692, 31259

Telex: 4282 MI

Telegrams: AGRIMAL

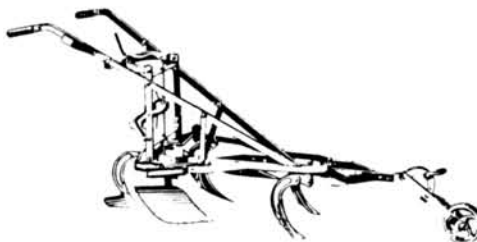

Description: The MC5 is designed for lighter cultivation than the Standard cultivator, although it is of similar configuration, with tines, tillers and a sweep. The width is adjustable by means of a crank-handle, whereas on the Standard it is by lever.

Price: (ex-works) (as at 1.2.80)

82.50 kwacha (\$100.00)

## RIDGER

### Manufactured by:

Agrimal (Malawi) Ltd  
PO Box 143  
BLANTYRE  
Malawi

Telephone: Blantyre 30692, 31259

Telex: 4282 MI

Telegrams: AGRIMAL



Description: This animal-drawn ridger/cultivator is suitable for ridging crops of maize, cotton, tobacco and potatoes. The wings of the ridging share can be adjusted to cultivate rows varying from 40 cm. to 75 cm. in width. Agrimal produce about 10,000 units of the ridger per annum.

Price: (ex-works) (as at 1.2.80)

72.50 kwacha (\$88.00)

---

(PRICES LATEST AVAILABLE FOR GUIDANCE ONLY. REFER MANUFACTURER FOR ACTUAL)

## 5-TINE CULTIVATOR

### Manufactured by:

Rhoplow Ltd  
PO Box 1059  
BULAWAYO  
Zimbabwe

Telephone: Bulawayo 71363

Telex: RH3372

Telegrams: RHOPLOW



Description: The cultivator comes in 2 forms:-

- (a) S 51 cultivator - fitted with 1 sweep, 2 hillers and 2 tines (as in the illustration).
- (b) Light cultivator - fitted with 1 sweep and 4 tines.

The light cultivator is for lighter cultivation and inter-row weeding, whilst the S51 can be used for heavier work. A ratchet and lever mechanism enables adjustment of the cultivator span.

Price: (wholesale) (as at 14.4.80)

1. S51	Zim\$59.00	(\$91.00)
2. Light	Zim\$55.00	(\$85.00)

## HIGH-WING RIDGER

### Manufactured by:

Rhoplow Ltd  
PO Box 1059  
BULAWAYO  
Zimbabwe

Description: The same beam and handle assembly of the Rhoplow ox-plough is fitted with adjustable ridging blades.

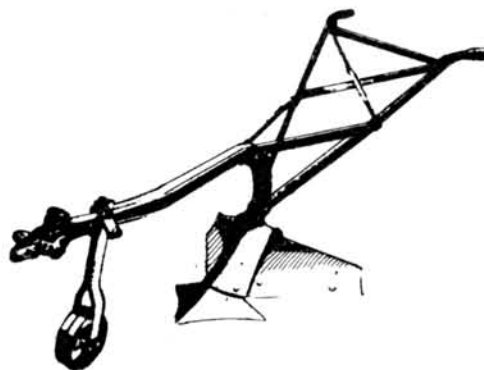

Price: (wholesale) (as at 14.4.80)

Zim\$60.50 (\$93.00)

---

(PRICES LATEST AVAILABLE FOR GUIDANCE ONLY. REFER MANUFACTURER FOR ACTUAL)

# HAND TOOLS

## AGRICULTURAL HAND TOOLS

### Manufactured by:

Kenya Engineering Industries Ltd  
 Nairobi Industrial Area  
 PO Box 18331  
 NAIROBI  
 Kenya

Telephone: Nairobi 559970/556395

Telex: AO 22866

Description: Kenya Engineering manufactures a range of agricultural and garden hand-tools, all with carbon steel blades and solid wooden handles. These are illustrated below, together with their price, (as at 1/5/80).



### Curved Machete

<u>Blade length</u>	<u>Price</u>
30cm.	Shg.14/10 (\$1.90)
40cm.	Shg.15/80 (\$2.10)
45cm.	Shg.17/00 (\$2.25)



### Straight Machete

<u>Blade length</u>	<u>Price</u>
40cm.	Shg.14/90 (\$2.00)
45cm.	Shg.16/30 (\$2.20)



### Garden Spade

Length: 106cm.  
Price: Shg.33/60 (\$4.50)



### Garden Rake

	<u>Price</u>
8 teeth	Shg.15/40 (\$2.05)
18 teeth	Shg.22/00 (\$2.95)
(Intermediate sizes available pro-rata)	



### Sugar-Cane Knife

Blade-length: 53cm.  
Price: Shg.21/00 (\$2.80)



### Shovels

<u>Round-mouth:</u>	Shg.33/60 (\$4.50)
<u>Square-mouth:</u>	Shg.31/80 (\$4.25)

---

(PRICES LATEST AVAILABLE FOR GUIDANCE ONLY. REFER MANUFACTURER FOR ACTUAL)

## AGRICULTURAL HAND TOOLS

### Manufactured by:

Agricultural Implements Manufacturers  
PO Box 1553  
NAKURU  
Kenya

Telephone: Nakuru 41672



Description: AIM manufacture a range of agricultural hand tools. There are: forked hoes, flat hoes and axes, and all come in different weights, and the hoes in different shapes. These differences are reflected in the price list.



Price: (retail) (as at 1.1.80)

½ kg. Fork Hoe (Round Head)	Kshg.27.60	(\$3.70)
1 kg. Fork Hoe (Hammer Head)	Kshg.38.40	(\$5.10)
1½ kg. Fork Hoe (Hammer Head)	Kshg.40.45	(\$5.40)
1 kg. Flat Hoe (Round Head)	Kshg.28.30	(\$3.80)
1 kg. Flat Hoe (Hammer Head)	Kshg.30.00	(\$4.00)
1½ kg. Flat Hoe (Round Head)	Kshg.29.05	(\$3.90)
1½ kg. Flat Hoe (Hammer Head)	Kshg.37.10	(\$5.00)

## AGRICULTURAL HAND TOOLS

### Manufactured by:

Ubungo Farm Implements Ltd (UFI)  
PO Box 20126  
DAR es SALAAM  
Tanzania

Telephone: Dar 53146-8

Telex: 41206 Dar es Salaam

Telegrams: MAJEMBE

Description: UFI manufacture both Round-eyed and Tanged Hoe Blades, in weights of 0.9 kg., 1.1 kg. and 1.3 kg.

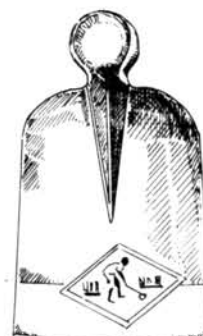

Price: (wholesale) (as at 1.1.80)

Round-eyed	from:	Tshg.25/10	(\$3.00)
Tanged	from:	Tshg.21/90	(\$2.70)

---

(PRICES LATEST AVAILABLE FOR GUIDANCE ONLY. REFER MANUFACTURER FOR ACTUAL)

## AGRICULTURAL HAND TOOLS

### Manufactured by:

Agrimal (Malawi) Ltd  
PO Box 143  
BLANTYRE  
Malawi

Telephone: Blantyre 30692, 31259

Telex: 4282 MI

Telegrams: AGRIMAL

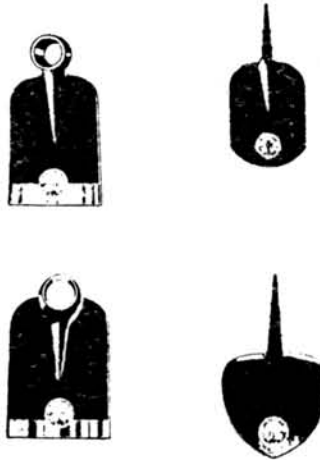

Description: Agrimal manufacture Tanged Hoes in different weights. They are sold in bundles of 10 units, but the prices below are for single units.

Price: (as at 1.4.80)

<u>Weight</u>	<u>Price</u>
0.7 kg.	1.40 kwacha (\$1.70)
0.9 kg.	1.60 kwacha (\$1.95)
1.1 kg.	1.85 kwacha (\$2.25)

### 'WINDOW' HOES (JEMBES)

#### Manufactured by:

Ideal Casements (E.A.) Ltd  
PO Box 45319  
NAIROBI  
Kenya

Telephone: Nairobi 555599/555319

Telegrams: IDEASMENT



Description: Ideal Casements manufacture a range of round-eyed and hammer-head hoes, of various sizes, from fully forged carbon steel. The various size of blades they produce are:

Round-eyed: 17x23, 15.5x21.5, 12x18 (cm)  
Hammer-head: 16.5x22, 15x21.5, 14x20, 12x18 (cm)

Price: (retail) (as at 1.4.80)

Kshg. 19.35 - 26.15 (\$2.60 - 3.50)

---

(PRICES LATEST AVAILABLE FOR GUIDANCE ONLY. REFER MANUFACTURER FOR ACTUAL)

"MEALIE BRAND" HOES

Manufactured by:

Rhoplow Ltd  
PO Box 1059  
BULAWAYO  
Zimbabwe

Telephone: Bulawayo 71363-5

Telex: RH3372

Telegrams: RHOPLOW

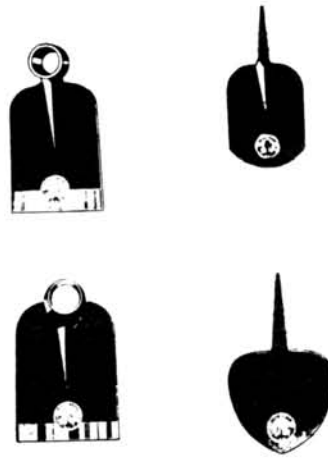

Description: Rhoplow manufacture a range of tang and ring headed hoes in different sizes. Hoes are sold in packets of 10 units and the prices below are shown per single unit, according to different sizes.

Prices: (ex-works) (as at 14.4.80)

0.6kg. Ring Hoe	Zim\$1.11	(\$1.70)
0.9kg. Ring Hoe	Zim\$1.46	(\$2.25)
1.1kg. Ring Hoe	Zim\$1.60	(\$2.46)
0.9kg. Sunken Head Ring Hoe	Zim\$1.46	(\$2.25)
1.1kg Sunken Head Ring Hoe	Zim\$1.65	(\$2.54)
0.45kg. Tang Hoe	Zim\$0.76	(\$1.17)
0.9kg. Tang Hoe	Zim\$1.11	(\$1.70)
1.35kg. Tang Hoe	Zim\$1.35	(\$2.08)
0.6kg. Heart Shaped Hoe	Zim\$0.86	(\$1.32)
0.8kg. Heart Shaped Hoe	Zim\$1.01	(\$1.55)

---

(PRICES LATEST AVAILABLE FOR GUIDANCE ONLY. REFER MANUFACTURER FOR ACTUAL)

# TOOLBARS & TRACTORS

## OCCIDENTALE TOOL BAR

### Manufactured by:

SISCOMA (Factory  
BP 3214 at Pout)  
DAKAR  
Senegal

Telephone: Pout 81096, 81136

Telex: 7781 SISCOMA SG

City Office: SISCOMA  
rue du Dr Theze/  
Grammont  
DAKAR  
Senegal

Telephone: 22375-84

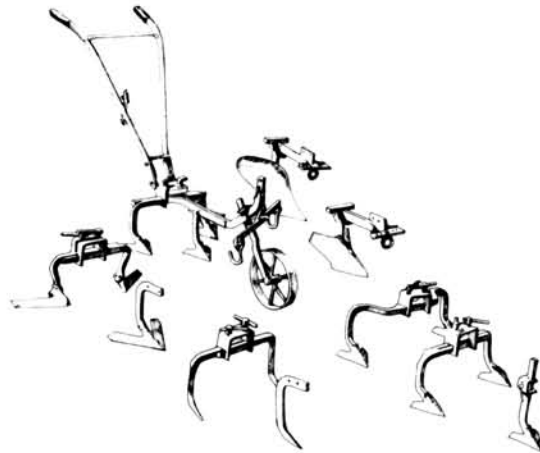

Description: The Occidentale is Siscoma's lightest tool bar and it is especially designed for horse and donkey draught. It can take the following tools:-

1x15 cm. plough blade  
1x25 cm. ridger  
3-5 hoeing tines  
3 duck-foot tines  
3 weeding blades  
1 two-row seed drill  
1 35 cm. lifting blade

Overall operational weight: 18-25 kg. (dependent on tools)

Price: (ex-works) (as at 1.1.80)

1. Basic equipment (hoeing/weeding)	15,750 CFA	(\$ 74.00)
2. Full equipment (except seeder)	35,215 CFA	(\$165.00)
3. Two-row seed drill	26,931 CFA	(\$126.00)

---

(PRICES LATEST AVAILABLE FOR GUIDANCE ONLY. REFER MANUFACTURER FOR ACTUAL)

## ARARA TOOL BAR

### Manufactured by:

SISCOMA (Factory  
BP 3214 at Pout)  
DAKAR  
Senegal

Telephone: Pout 81096, 81136

Telex: 7781 SISCOMA SG

City Office: SISCOMA  
rue de Dr Theze/  
Grammont  
DAKAR  
Senegal

Telephone: 22375-84



Description: The Arara is one of Siscoma's 2 medium weight tool bars, the lightest range they manufacture for ox-draught. It is the simplest of the 2, in terms of equipment it takes, and in terms of the adjustability of width. It is however, the only Siscoma tool bar with a handle whose height is adjustable, in the vertical axis. It takes the following tools:-

- 1x25 cm. plough share
- 1 ridging plough, adjustable blades
- 1 set of groundnut lifting blades
- 1 set of 3 'Canadian' tines
- or 1 set of 5 'Canadian' tines
- 2x2 row seed drills (Super Eco)

Overall operational weight: 31-46 kg. (dependent on tools)

Price: (ex-works) (as at 1.1.80)

1. Basic equipment (frame only)	16,570 CFA	(\$ 78.00)
2. Full equipment (except seeder)	70,250 CFA	(\$330.00)
3. 2x2 row seed drill	62,830 CFA	(\$294.00)

---

(PRICES LATEST AVAILABLE FOR GUIDANCE ONLY. REFER MANUFACTURER FOR ACTUAL)

## SINE TOOL BAR (HOUE SINE)

### Manufactured by:

SISCOMA (Factory  
BP 3214 at Pout)  
DAKAR  
Senegal

Telephone: Pout 81096, 81136

Telex: 7781 SISCOMA SG

City Office: SISCOMA  
rue du Dr Theze/  
Grammont  
DAKAR  
Senegal

Telephone: 22375-84

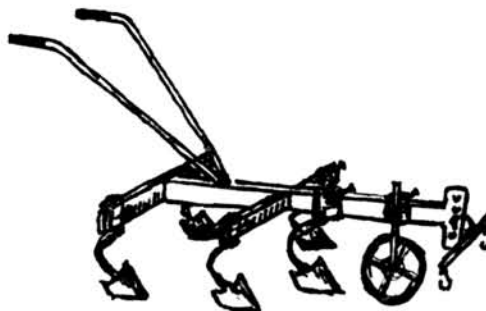

Description: The Sine is one of Siscoma's 2 medium weight tool bars, the lightest range they manufacture for ox-draught. The Sine is more sophisticated than the Arara permitting more adjustment of operational height and width and the additional alternative of chisel-tines. An adaption of the basic design has also been made at the factory to meet specific conditions in the Gambia where the Sine is being used. It takes the following tools:-

- 1 20 cm. or 25 cm. plough share
- 1 ridging plough, adjustable blades
- 1 set of groundnut lifting blades
- 1 set of 3 'Canadian' tines
- or 1 set of 5 'Canadian' tines
- 2x2 row seed drills

Overall operational weight: 30-45 kg. (dependent on tools)

Price: (ex-works) (as at 1.1.80)

1. Basic equipment (frame with 'Canadian' tines)	23,912 CFA (\$112.00)
2. Full equipment (except seeder) approximately	69,500 CFA (\$326.00)
3. 2x2 row seed drill	62,830 CFA (\$294.00)

---

(PRICES LATEST AVAILABLE FOR GUIDANCE ONLY. REFER MANUFACTURER FOR ACTUAL)

## SINE-HOUE TOOL-FRAME

### Manufactured by

Ploughs & Allied Products Ltd  
PO Box 467  
KISUMU  
Kenya

Telephone: Kisumu 40512

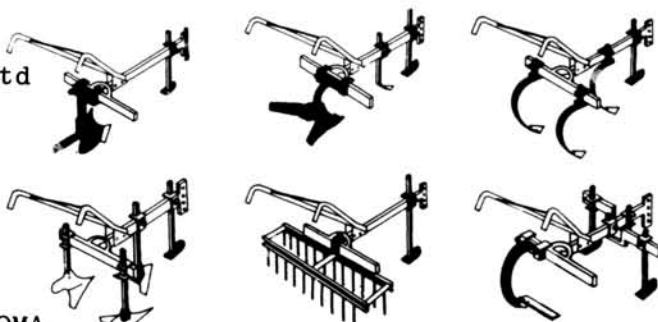

Description: (see entry for SINE-HOUE manufactured by SISCOMA, Senegal for greater detail)

Ploughs & Allied Products are making the Sine-Houe tool-frame of Senegalese design, and are able to manufacture the whole frame from locally available materials. In the last year they produced more than 100 units.

Price: (ex-works) Kshg. 1200/00 (\$160.00)  
(as at 1.7.80)

## GRECO TOOL-BAR

### Manufactured by:

SISCOMA (Factory  
BP 3214 at Pout)  
DAKAR  
Senegal

### City Office:

SISCOMA  
rue du Dr Theze/Grammont  
DAKAR  
Senegal

Tel: 22375-84

Tel: Pout 81096/81136

Telex: 7781 SISCOMA SG

Description: The Greco has the design of the Sine Tool bar, but the frame is heavier. It will take all the fitments made for the Sine, and the wheel-bearings are nylon instead of iron.

Price: (Ex-works) (as at 1.1.80)

1. Basic equipment (frame with 'Canadian' tine) 25,656 CFA (\$120.00)
2. Full equipment (except seeder) approximately 71,244 CFA (\$334.00)

---

(PRICES LATEST AVAILABLE FOR GUIDANCE ONLY. REFER MANUFACTURER FOR ACTUAL)

## ARIANA TOOL BAR

### Manufactured by:

SISCOMA (Factory  
BP 3214 at Pout)  
DAKAR  
Senegal

Telephone: Pout 81096, 81136

Telex: 7781 SISCOMA SG

City Office: SISCOMA  
rue de Dr Theze/  
Grammont  
DAKAR  
Senegal

Telephone: 22375-84

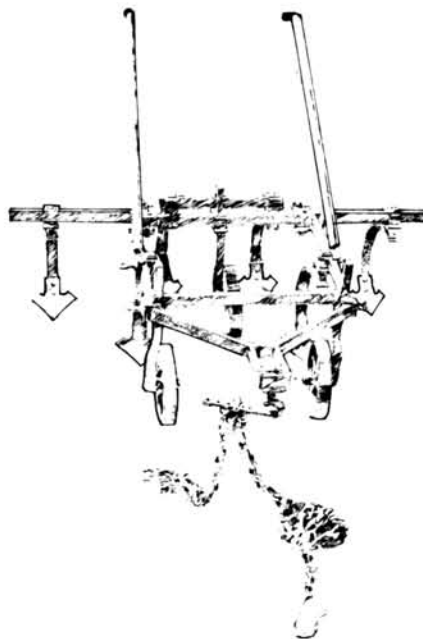

Description: The Ariana is perhaps Siscoma's most well-known tool bar, a reputation it enjoys for its versatility and relative ease of operation. The Ariana frame is designed for stability, giving it this reputation, a stability that persists when the tool bar is used in heavy soils and paddy fields. The basic frame is quadrilateral, it rests on 3 wheels and is guided by two independent handles and an adjustable draught-chain mounting. It takes the following tools:-

- 1 or 2 25 cm. cut-away plough shares
- or 1 25 cm. quarter-trim plough share
- 1 ridging plough, adjustable blades
- 1 set of groundnut lifting blades
- 1 set of 6-8 'Canadian' tines
- 1 1.5 m. extension bar

Overall operational weight: 58-92 kg. (dependent on tools)

Price: (ex-works) (as at 1.1.80)

- |  |                        |
|--|------------------------|
| 1. Basic frame (wheels, extension bar, chain, handles) | 39,420 CFA (\$185.00)  |
| 2. Full equipment                                      | 159,319 CFA (\$748.00) |

---

(PRICES LATEST AVAILABLE FOR GUIDANCE ONLY. REFER MANUFACTURER FOR ACTUAL)

## BAOL TOOL BAR

### Manufactured by:

SISCOMA (Factory  
BP 3214 at Pout)  
DAKAR  
Senegal

Telephone: Pout 81096, 81136

Telex: 7781 SISCOMA SG

City Office: SISCOMA  
rue de Dr Theze/  
Grammont  
DAKAR  
Senegal

Telephone: 22375-84

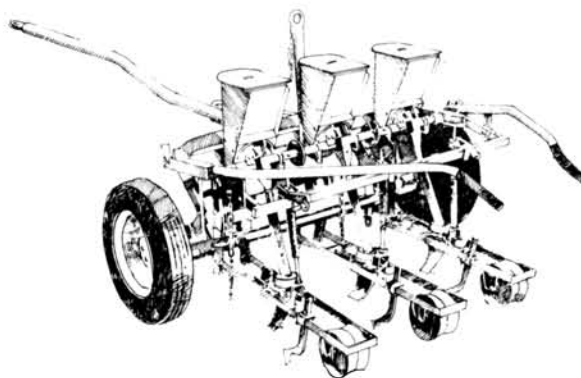

Baol tool-bar with drill

Description: The Baol tool bar is a heavy duty axle with 2 pneumatic tyres and a solid draught bar, which is swivel mounted. Its operation requires high draught or low drag conditions and its configuration is similar to tractor drawn tool bars; thus it is a useful transition tool to motorized cultivation.

It takes the following tools:-

- 1 25 cm. plough share
- 2 ridging ploughs, adjustable blades
- 2 sets of groundnut lifting blades
- 1 2 m. articulated extension tool bar with
- 1 set of 8-12 'Canadian' tines
- 1 tippable cart-top
- 1 set of 3 row Super Eco seed drills

Prices: (ex-works) (as at 1.1.80)

1. Basic toolbar chassis	104,160 CFA	(\$ 489.00)
2. Full equipment (as above)	402,281 CFA	(\$1888.00)

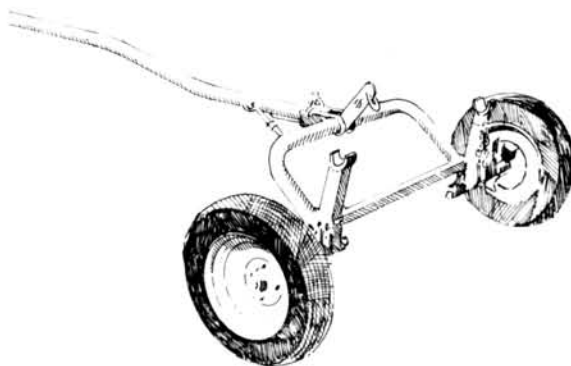

Baol tool-bar chassis

---

(PRICES LATEST AVAILABLE FOR GUIDANCE ONLY. REFER MANUFACTURER FOR ACTUAL)

## MAKGONATSOTLHE TOOL-BAR

### Manufactured by:

Kgatlang Development Board  
PO Box 208  
MOCHUDI  
Botswana

Telephone: Mochudi 356

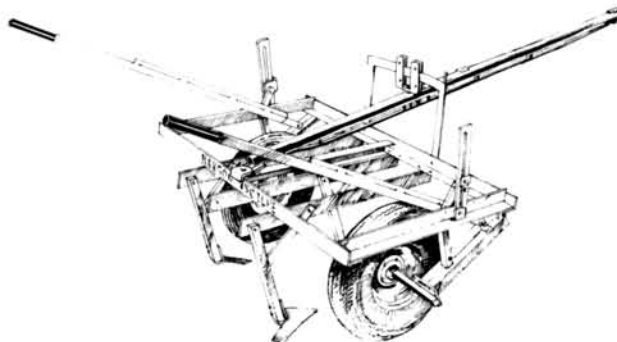

Description: The Makgonatsothlhe Tool-Bar has been developed from designs of existing multi-purpose tool-bars. It is perhaps unique in that it has been designed for either ox or donkey draught.

It is designed to be fitted with: planter, disc-cultivator, sweeps for minimum tillage, fertilizer applicator, water-drums (for water transport) and a scotch-cart frame.

The basic frame of the tool-bar is made from heavy angle iron, and the rubber-tyred wheels are mounted on stub-axles. Implements are attached to the main frame with sub-frames which can be positioned variably at any position on the main frame. This enhances the adaptability of the machine: e.g. by being capable of bearing either one or two planter units for single or double row planting.

Price: (retail) (as at 1.7.80)

1. Complete with all attachments except planter: 600 pula (\$759.00)
2. Planter attachment: 180 pula (\$228.00)

---

(PRICES LATEST AVAILABLE FOR GUIDANCE ONLY. REFER MANUFACTURER FOR ACTUAL)

## TINKABI TRACTOR

### Manufactured by:

Tinkabi Tractor Project  
NIDCS  
Box 450  
MANZINI  
Swaziland

Telephone: 52141

Telex: 2127 WD



Description: Tinkabi is a design of small tractor unique in Africa. It is powered by a 15 h.p. diesel engine and has a hydro-static transmission which controls speed, backward and forward motion and braking with a single movement of a hand lever. That and the steering wheel are the only operational controls, which makes operation extremely simple. The simple mechanical design of the tractor also permits a long engine life with a minimum of servicing: and combined with the low capital cost makes Tinkabi a cheap alternative to a conventional tractor.

Forward of the driver is a large platform which can transport loads of up to 500 kg., and at the rear of the tractor is a tool bar, to which can be fitted a full range of cultivation equipment. There is also a belt-drive power take-off on the engine and Tinkabi can be supplied with both a water-pump and a maize hammer-mill which can be powered from this source.

Price: Unavailable

---

(PRICES LATEST AVAILABLE FOR GUIDANCE ONLY. REFER MANUFACTURER FOR ACTUAL)

# HARROWS

## HARROWS

Triangular, Diamond and Zig-zag

### Manufactured by:

Agrimal (Malawi) Ltd  
PO Box 143  
BLANTYRE  
Malawi

Telephone: Blantyre 30692, 31259

Telex: 4282 MI

Telegrams: AGRIMAL

Description: Triangular, Diamond and Zig-zag Harrows are produced by Agrimal. The Diamond and Zig-zag harrows are available in sets of 2, 3 or 4 depending on the power source available and the type of cultivation. Prices vary according to the type and size of harrow.

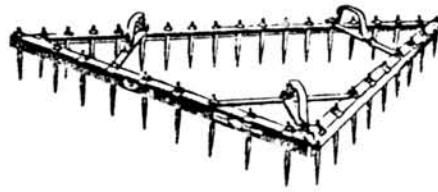

Triangular Harrow

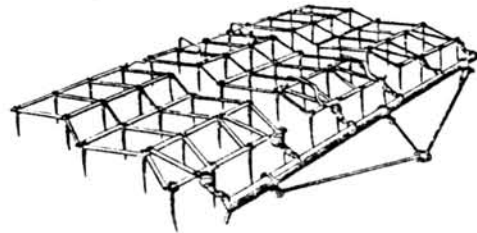

Diamond Harrow

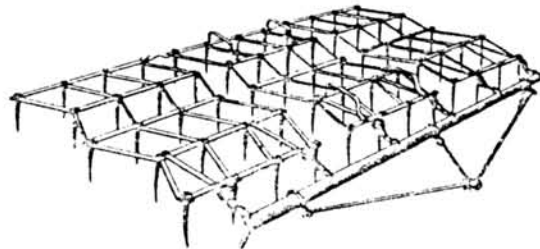

Zig-Zag Harrow

### Prices: (as at 1.4.80)

Triangular Harrow	47.50 kwacha	(\$ 58.00)
2 section Diamond + Drawbar	81.90 kwacha	(\$100.00)
3 " " " "	116.70 kwacha	(\$142.00)
4 " " " "	157.80 kwacha	(\$192.00)
2 section Zig-zag + Drawbar	147.30 kwacha	(\$180.00)
3 " " " "	217.80 kwacha	(\$266.00)
4 " " " "	292.60 kwacha	(\$357.00)

---

(PRICES LATEST AVAILABLE FOR GUIDANCE ONLY. REFER MANUFACTURER FOR ACTUAL)

## ROTARY HARROW

### Manufactured by:

SISCOMA (Factory  
BP 3214 at Pout)  
DAKAR  
Senegal

Telephone: Pout 81096, 81136

Telex: 7781 SISCOMA SG

City Office: SISCOMA  
rue du Dr Theze/  
Grammont  
DAKAR  
Senegal

Telephone: 22375-84

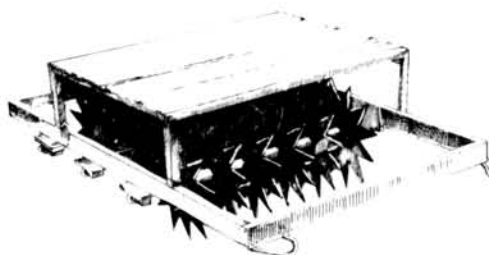

Description: The Rotary Harrow consists of 2 axles of spike-toothed wheels mounted in a frame. The width of cultivation is 1 m. and depth of cultivation 20 cm. A platform is mounted above the harrow, on which the operator can stand to increase the weight.

Price: (as at 1.1.80) 65,840CFA (\$309.00)

## ZIG-ZAG HARROW

### Manufactured by:

SISCOMA (Factory  
BP 3214 at Pout)  
DAKAR  
Senegal

Telephone: Pout 81096, 81136

Telex: 7781 SISCOMA SG

Description: A zig-zag harrow with a double set mounted on a drawbar, supplied with a sled for transport.

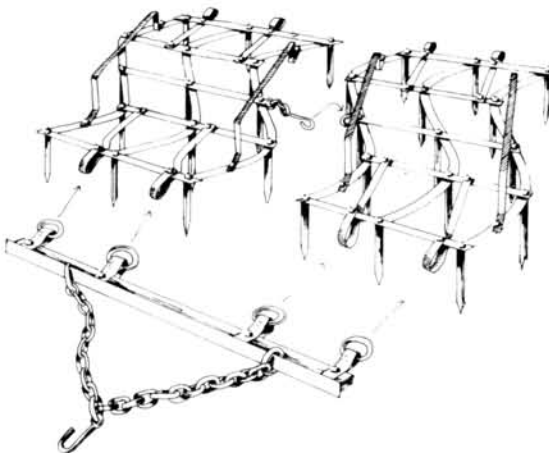

Price: (as at 1.1.80) 30,974 CFA (\$145.00)

---

(PRICES LATEST AVAILABLE FOR GUIDANCE ONLY. REFER MANUFACTURER FOR ACTUAL)

## RECTANGULAR HARROW

### Manufactured by:

TAMTU  
Box 1389  
ARUSHA  
Tanzania

Telephone: Arusha 3666

Telegrams: TAMTU

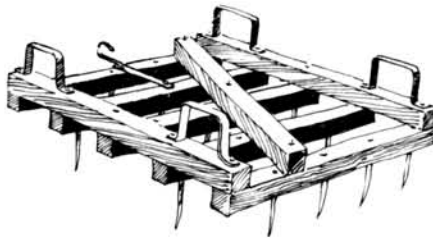

Description: The TAMTU harrow is made from a heavy 10cm x 10cm timber frame, fixed with cross-members. To these are attached heavy duty steel spikes that protrude 15cm. On the top of the frame are fixed steel slides so that the harrow can be inverted for transport as a sled.

Price: (retail) (as at 1.5.80)

Tshg. 700.00 (\$86.00)

---

(PRICES LATEST AVAILABLE FOR GUIDANCE ONLY. REFER MANUFACTURE FOR ACTUAL)

## HARROWS

### Manufactured by:

Rhoplow Limited  
 P O Box 1059  
 BULAWAYO  
 Zimbabwe

Telephone: Bulawayo 71363-5

Telex: RH3372

Telegrams: RHOPLOW

Description: A standard range of harrows, of which the diamond and the zig-zag are available in sets of 2, 3 or 4 sections.

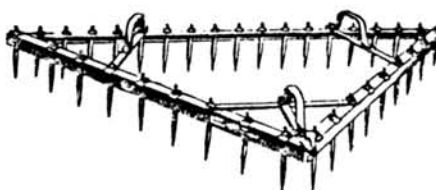

Triangular Harrow

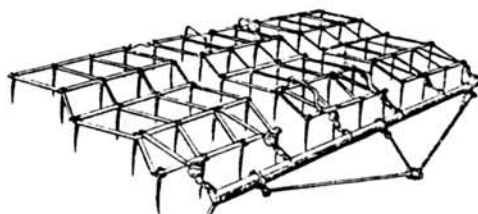

Diamond Harrow

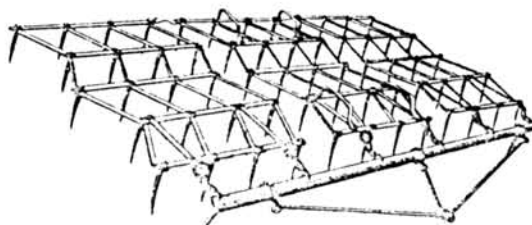

Zig-Zag Harrow

### Prices: (ex-works) (as at 14.4.80)

Triangular Harrow	Zim\$ 37.50	(\$ 58.00)
2 section Diamond Harrow + Drawbar	Zim\$ 65.77	(\$101.00)
3 " " " "	Zim\$ 99.02	(\$152.00)
4 " " " "	Zim\$133.17	(\$205.00)
2 section Zig-Zag Harrow + Drawbar	Zim\$111.80	(\$172.00)
3 " " " "	Zim\$167.91	(\$258.00)
4 " " " "	Zim\$225.23	(\$346.50)

---

(PRICES LATEST AVAILABLE FOR GUIDANCE ONLY. REFER MANUFACTURER FOR ACTUAL)

# SEEDERS

## CASAMANCE SEED-DRILL (PADDY)

Manufactured by:

SISCOMA (Factory  
BP 3214 at Pout)  
DAKAR  
Senegal

Telephone: Pout 81096, 81136

Telex: 7781 SISCOMA SG

City Office: SISCOMA  
rue du Dr Theze/  
Grammont  
DAKAR  
Senegal

Telephone: 22375-84

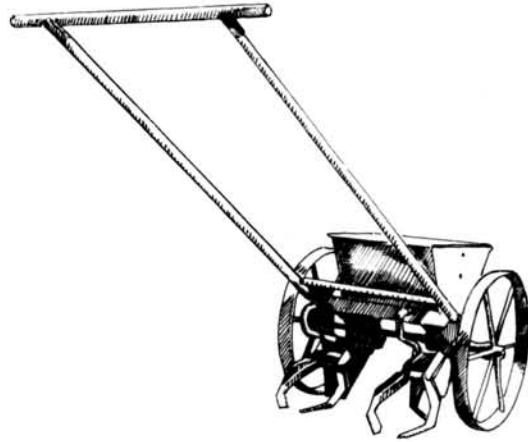

Description: The Casamance is designed for paddy planting, and manual operation only. It will sow all varieties of rice seed, at rates varying between 0-130 seeds per running metre.

Price: (as at 1.1.80) 17,730 CFA (\$83.00)

## KOLDA SEED-DRILL (PADDY)

Manufactured by:

SISCOMA (Factory  
BP 3214 at Pout)  
DAKAR  
Senegal

Telephone: Pout 81096, 81136

Telex: 7781 SISCOMA SG



Description: The Kolda is for paddy planting, and is designed for donkey draught. It is equipped with seeders in 3 fixed rows, spaced at 25 cm.

Price: (as at 1.1.80) 26,931 (\$126.00)

---

(PRICES LATEST AVAILABLE FOR GUIDANCE ONLY. REFER MANUFACTURER FOR ACTUAL)

## MOPTI SEED-DRILL (PADDY + WHEAT)

### Manufactured by:

SISCOMA (Factory  
BP 3214 at Pout)  
DAKAR  
Senegal

Telephone: Pout 81096, 81136

Telex: 7781 SISCOMA SG

City Office: SISCOMA  
rue du Dr Theze/  
Grammont  
DAKAR  
Senegal

Telephone: 22375-84

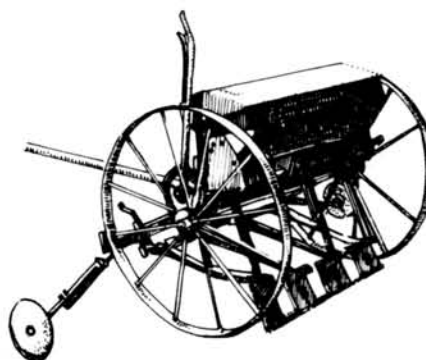

Description: The Mopti is for paddy or wheat planting, and donkey or horse draught. It can be fitted with either 4 or 7 seeding coulters, spaced between 20 and 40 cm., which are designed for precision planting.

<u>Price:</u> (as at 1.1.80)	4 row Mopti	295,000 CFA	(\$1385.00)
	7 row Mopti	316,000 CFA	(\$1484.00)

## SINGLE-ROW PLANTER

### Manufactured by:

Agrimal (Malawi) Ltd  
PO Box 143  
BLANTYRE  
Malawi

Telephone: Blantyre 30692, 31259

Telex: 4282 MI

Telegrams: AGRIMAL

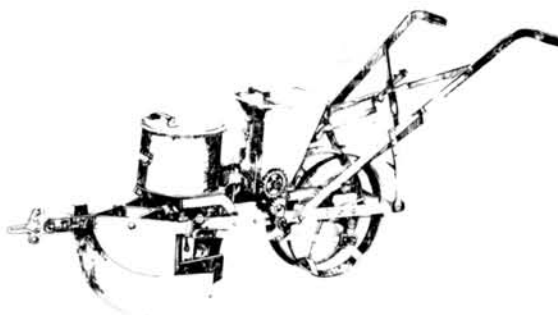

Description: The Agrimal planter is of simple and rugged construction and a double pitman drive operates the planting wheel, which ensures positive seeding. Several optional extras are available for the planter: fertiliser spreader, cotton-seed planter and a range of seed plates suitable for all sizes of maize, millet, sorghum and legume seeds.

<u>Price:</u> (as at 1.1.80)	168.40 kwacha	(\$205.00)
------------------------------	---------------	------------

---

(PRICES LATEST AVAILABLE FOR GUIDANCE ONLY. REFER MANUFACTURER FOR ACTUAL)

## SUPER ECO SEED-DRILL

(with SUPER-ECO or TAMBA HOPPERS)

### Manufactured by:

SISCOMA (Factory  
BP 3214 at Pout)  
DAKAR  
Senegal

Telephone: Pout 81096, 81136

Telex: 7781 SISCOMA SG

City Office: SISCOMA  
rue du Dr Theze/  
Grammont  
DAKAR  
Senegal

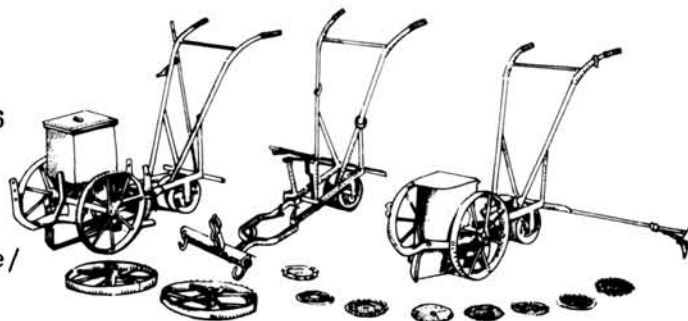

Telephone: 22375-84

Description: The Super-Eco seed-drill is a hand-guided seeder for all types of animal draught to which can be attached both the Super-Eco and the Tamba hoppers.

The Super-Eco hopper is for sowing all grains and legumes and can be fitted with interchangeable discs for seeds of different sizes.

The Tamba hopper is specially designed for sowing undelinted cotton seed.

The Super-Eco seed drill frame is fitted with a tracer adjustable up to 80 cm. spacing.

Price: (as at 1.1.80)

1. Super-Eco seeder, with Super-Eco hopper:	31,415 CFA	(\$147.00)
2. Super-Eco seeder, with Tamba hopper:	34,155 CFA	(\$160.00)
3. <u>Each</u> seeding plate (all supplementary)	1,050 CFA	(\$ 5.00)

---

(PRICES LATEST AVAILABLE FOR GUIDANCE ONLY. REFER MANUFACTURER FOR ACTUAL)

## MOCHUDI SEEDER

### Manufactured by:

Mochudi Brigade  
PO Box 248  
MOCHUDI  
Botswana

Telephone: Mochudi 912

Telegrams: BRIGADES, MOCHUDI

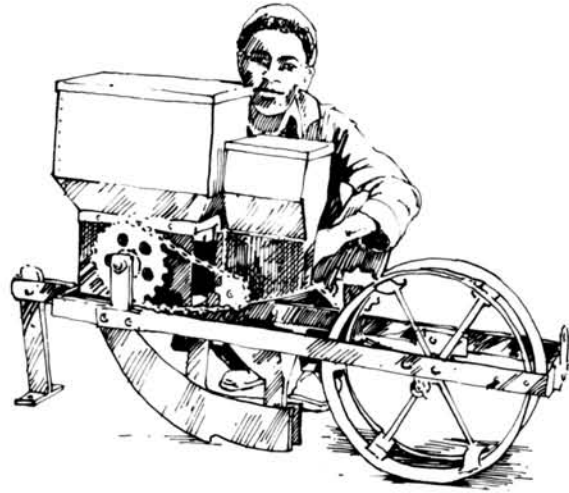

Description: The planter is based on a 'seed and agitator' design of seed hopper, which will meter and plant a wide range of seed sizes without blockage. It can be used with ungraded seed, and good results have been obtained with millet, sorghum, cowpeas, sunflowers and maize, although it should be noted that it is not a precision spacing planter. Seed depth is controlled either by an adjustable mounting on a toolbar, or by skids in the single row version. Seed-covering is achieved by the 40cm. diameter split-rim wheel.

Price: (retail) (as at 1.7.80)

75.00 pula (\$98.00)

---

(PRICES LATEST AVAILABLE FOR GUIDANCE ONLY. REFER MANUFACTURER FOR ACTUAL)

## TAMTU HAND PLANTER

### Manufactured by:

TAMTU  
PO Box 1389  
ARUSHA  
Tanzania

Telephone: Arusha 3666

Telegrams: TAMTU

Description: The hand planter is a jab planter with wooden handles and a wooden slide seed metre. The jabbing action automatically meters seeds into the planting hole.

Price: Tshg.85.00 (\$10.00)



## TAMTU OX-DRAWN PLANTER

### Manufactured by:

TAMTU  
PO Box 1389  
ARUSHA  
Tanzania

Telephone: Arusha 3666

Telegrams: TAMTU

Description: The TAMTU ox-drawn planter is a heavy duty ox-drawn planter with 2 hoppers mounted in tandem : one for seed, the other for fertiliser. The frame is made from welded tubular steel.

Price: (as at 1.1.80) Tshg.1500.00 (\$185.00)

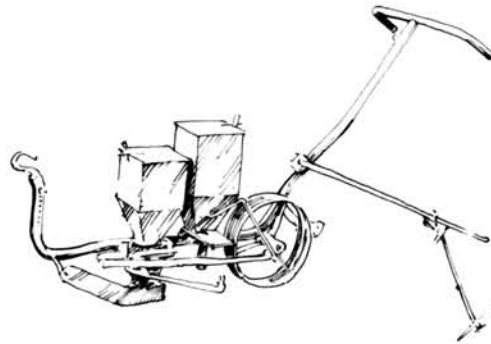

---

(PRICES LATEST AVAILABLE FOR GUIDANCE ONLY. REFER MANUFACTURER FOR ACTUAL)

## ROTARY INJECTION PLANTER

### Manufactured by:

Agricultural Implements Manufacturers Ltd  
PO Box 1553  
NAKURU  
Kenya

Telephone: Nakuru 41672

Description: Manufactured to a design by the International Institute of Tropical Agriculture at Ibadan in Nigeria, this planter is specifically designed for use in minimum tillage cultivation. Therefore it is best used in combination with no-till primary preparation by herbicide weed killing, followed by injection planting of seeds through the detritus (which forms a mulch). Seeds are distributed from an axial hopper through seeding channels on the wheel rim, which themselves incorporate a slide to tamp down the soil after injection of a seed.

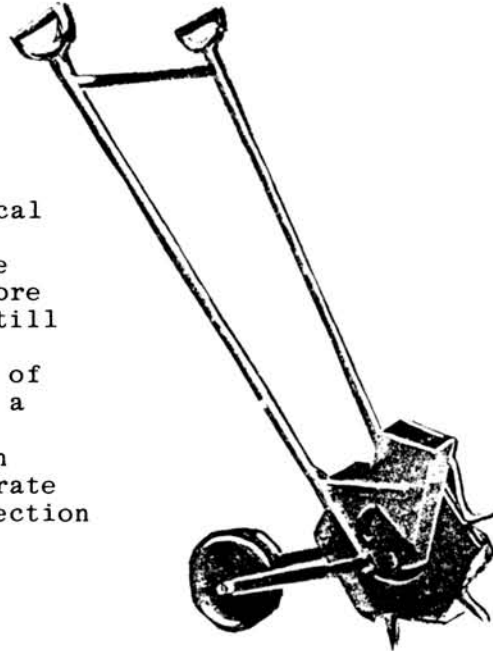

Price: (approximately) (as at 1.1.80)

Kshg.270.00 (\$36.00)

## HAND PLANTER

### Manufactured by:

Brown & Clapperton Ltd  
PO Box 52  
BLANTYRE  
Malawi

Telephone: Blantyre 34677

Telex: 4243

Telegrams: BEANCE

Description: The Brown & Clapperton hand planter is a jab planter made from wood and metal, which meters the seed into the planting hole by means of a wooden slide.

Price: (retail) (as at 1.7.80) 16 kwacha (\$19.50)

---

(PRICES LATEST AVAILABLE FOR GUIDANCE ONLY. REFER MANUFACTURER FOR ACTUAL)

# HARVESTERS

## 'BORNU' GROUNDNUT-LIFTER

### Designed by:

Farm Machinery Research Unit  
Regional Research Station  
PO Box 11  
MAGOYE  
Zambia

Telephone: Magoye 420

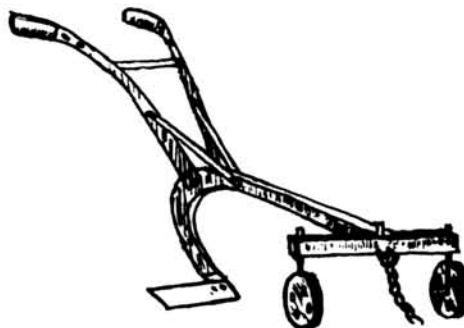

Description: The 'Bornu' Groundnut-lifter is merely a blade that can be attached to the standard 'Victory' mouldboard type of ox-plough frame. The adaption, therefore, is limited to the blade, which can be bolted on in place of a mouldboard, and an extra wheel and axle-bar in place of the single wheel of a plough.

The lifter was originally developed in Nigeria, hence the name, where it is used, and the design was brought to Zambia. It is designed for lifting groundnuts which have been planted in 1 metre ridges, and in normal use can harvest about 1.2 hectares per day.

The lifter blade must be made from high grade steel - such as an old lorry spring, or a slasher blade - and can be easily shaped by local blacksmiths.

Price: (cost of production)                      20 kwacha (\$25.00)

---

(PRICES LATEST AVAILABLE FOR GUIDANCE ONLY. REFER MANUFACTURER FOR ACTUAL)

## CHITEDZE GROUNDNUT LIFTER

### Designed by:

Chitedze Research Station  
Ministry of Agriculture &  
Natural Resources  
P O Box 158  
LILONGWE  
Malawi

Telephone: Lilongwe 721855

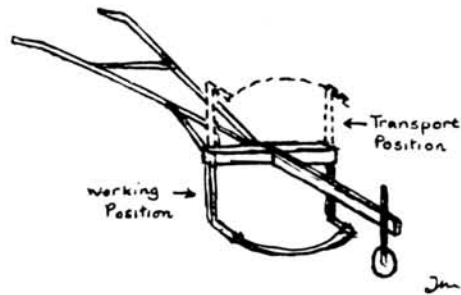

Description: The Chitedze Research Station has designed a model of groundnut lifter as a light-weight alternative to the double-beam design that is also being produced. The Chitedze model is also designed for easy transport when the implement is not in use, as the blade

can be unmounted and re-positioned above the beam for movement between fields. Furthermore, the mounting of the single front wheel is so designed that, with the line of draught passing through the centre of resistance of the blade, the wheel has no function, and consequently no drag, when the blade is in operation. The wheel is thus only used as a pivot when turning at the end of a line, or during movement outside the field. All components of the lifter can be made from easily available steel sections with simple smithy techniques.

Price: (cost of production) 20 kwacha (\$24.50)

## GROUNDNUT LIFTER

### Manufactured by:

Agrimal (Malawi) Ltd  
PO Box 143  
BLANTYRE  
Malawi

Telephone: Blantyre 30692, 31259

Telex: 4282 MI

Telegrams: AGRIMAL

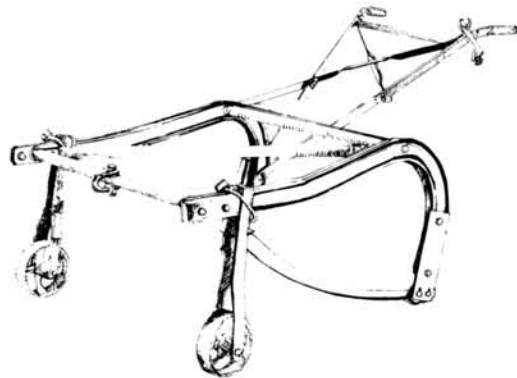

Description: Agrimal manufacture a robust groundnut lifter, whose design incorporates 2 plough beams spaced apart with a groundnut lifting blade. The weight of the implement is 54 kg., and Agrimal produce about 500 units per annum.

Price: (as at 1.1.80) 95.00 kwacha (\$116.00)

---

(PRICES LATEST AVAILABLE FOR GUIDANCE ONLY. REFER MANUFACTURER FOR ACTUAL)

# THRESHING, WINNOWER, CRACKING, SHELLING

## MAIZE SHELLER

### Manufactured by:

SISCOMA (Factory  
BP 3214 at Pout)  
DAKAR  
Senegal

Telephone: Pout 81096, 81136

Telex: 7781 SISCOMA SG

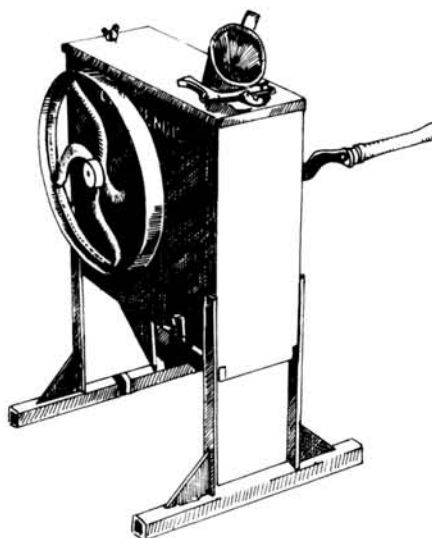

Description: Two models are available: a small (manual) model whose capacity is 80-100kg. grain/hour, and a large model (manual or motor-driven) whose capacity is 150-200kg./hour.

Prices: (as at 1.1.80)

1. Small manual	7,010 CFA	(\$ 33.00)
2. Large manual	64,596 CFA	(\$303.00)
3. Large motor driven	190,016 CFA	(\$892.00)

## GROUNDNUT SHELLER

### Manufactured by:

Agrimal (Malawi) Ltd  
PO Box 143  
BLANTYRE  
Malawi

Telephone: Blantyre 30692, 31259

Telex: 4282 MI

Telegrams: AGRIMAL

Description: The Agrimal groundnut-sheller is a reciprocating decorticator equipped with inter-changeable screens for groundnuts of different size.

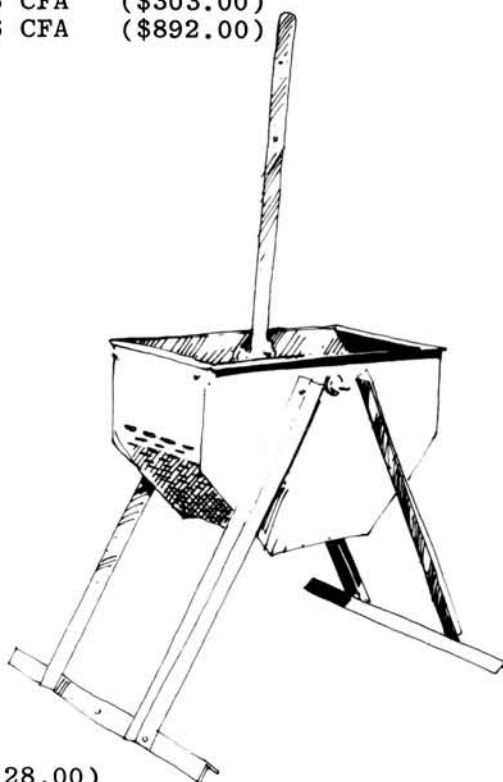

Price: (as at 1.4.80) 105.00 kwacha (\$128.00)

---

(PRICES LATEST AVAILABLE FOR GUIDANCE ONLY. REFER MANUFACTURER FOR ACTUAL)

## HAND MAIZE SHELLER

### Manufactured by:

Brown & Clapperton Ltd  
PO Box 52  
BLANTYRE  
Malawi

Telephone: Blantyre 34677

Telex: 4243

Telegrams: BEANCE



Description: A compact maize-sheller for hand-operation that can be fitted to the side of a container, allowing the kernels to drop into the container, and passing the shelled cobs out to the side. Tension is adjustable according to the diameter of the maize cobs.

Price: (as at 30 kwacha (\$36.00)  
1.7.80)

## GROUNDNUT SHELLER

### Manufactured by:

Ubungo Farm Implements Ltd (UFI)  
PO Box 20126  
DAR es SALAAM  
Tanzania

Telephone: Dar 53146-8

Telex: 41206 Dar es Salaam

Telegrams: MAJEMBE

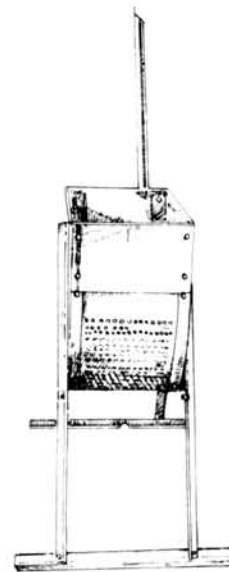

Description: The groundnut sheller is a hand-operated reciprocating design, with interchangeable screens. The potential capacity is 25-30kg./hour.

Price: (retail) (as at 1.1.80) Tshg.275.00 (\$34.00)

---

(PRICES LATEST AVAILABLE FOR GUIDANCE ONLY. REFER MANUFACTURER FOR ACTUAL)

## CHITEDZE GROUNDNUT CRACKER

### Manufactured by:

Chitedze Research Station  
Ministry of Agriculture &  
Natural Resources  
PO Box 158  
LILONGWE  
Malawi

Telephone: Lilongwe 721855

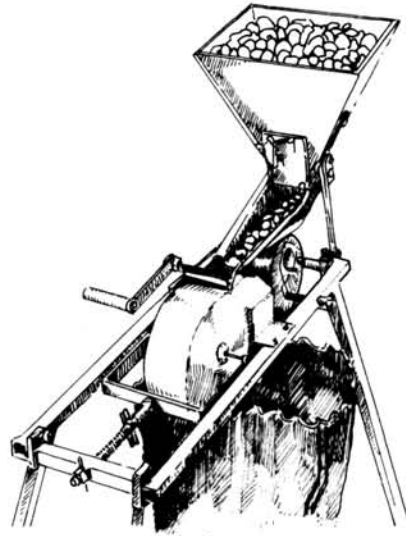

Description: The groundnut cracker has been developed for cracking the shells of groundnuts before hand-shelling, as Malawi produces a large amount of 'Chalimbana' groundnuts for the confectionery trade. These are larger than the ordinary groundnut and can be damaged when processed with available groundnut shellers. 10% would be the maximum acceptable level of damage for these nuts: therefore they are shelled by hand.

The machine consists of 2 wheels, held together by spring-tension, which are covered with rubber from old inner-tubes. A hopper feeds the nuts between the wheels, which are cranked steadily to process the nuts. In setting the spring-loading, a balance must be struck between 100% undamaged nuts and 100% cracked shells: obviously a strong loading would crack all shells, but damage some nuts whereas a weak loading would damage no nuts but leave some shells uncracked. Tests have shown that 5% damage can be matched with 8% uncracking: whilst 12kg. of nuts can be cracked per hour.

Price: (cost of production)                      30 kwacha    (\$33.00)

---

(PRICES LATEST AVAILABLE FOR GUIDANCE ONLY. REFER MANUFACTURER FOR ACTUAL)

## CAYOR ROTARY GROUNDNUT THRESHER

### Manufactured by:

SISCOMA (Factory  
BP 3214 at Pout )  
DAKAR  
Senegal

Telephone: Pout 81096, 81136

Telex: 7781 SISCOMA SG

City Office: SISCOMA  
rue du Dr Theze/  
Grammont  
DAKAR  
Senegal

Telephone: 22375-84

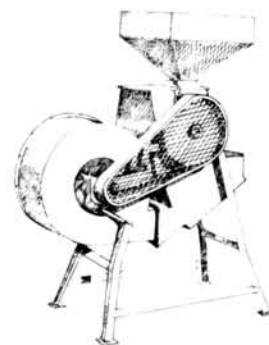

Description: The Cayor thresher is supplied with interchangeable screens and can be operated manually, or by power-take off. The potential capacity is 150kg. kernels/hour.

The 'Super Cayor' thresher is supplied with a winnowing fan.

Prices: (as at 1.1.80)

1. Cayor	55,802 CFA	(\$262.00)
2. Super Cayor	82,560 CFA	(\$388.00)

## SENEGAL SCREEN GROUNDNUT THRESHER

### Manufactured by:

SISCOMA (Factory  
BP 3214 at Pout )  
DAKAR  
Senegal

Telephone: Pout 81096, 81136

Telex: 7781 SISCOMA SG

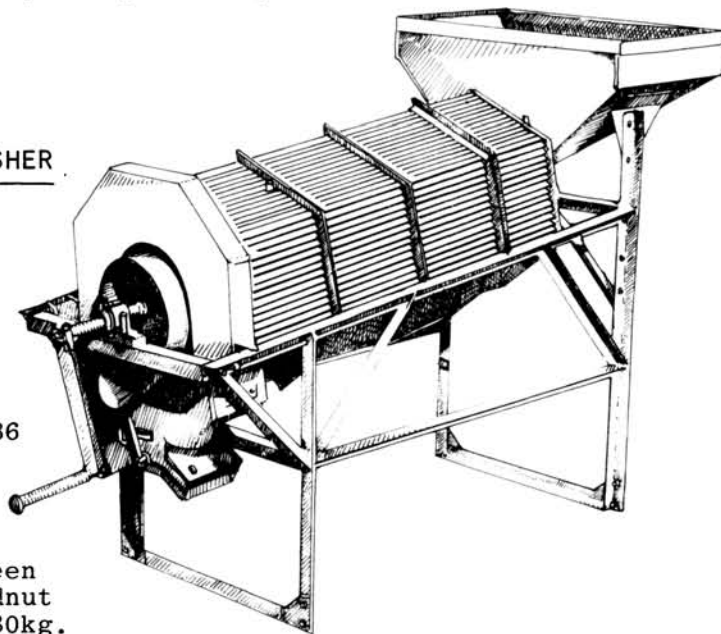

Description: The Senegal screen cracks and decorticates groundnut pods. Pods are fed from the 80kg. capacity hopper down the rotating drum and the shelled kernels gravitate to two outlets for sack-filling. The potential capacity is 1500kg./hour with manual operation.

Price: (as at 1.1.80) 145,200 CFA (\$682.00)

---

(PRICES LATEST AVAILABLE FOR GUIDANCE ONLY. REFER MANUFACTURER FOR ACTUAL)

## ALTERNATING GROUNDNUT THRESHER

### Manufactured by:

SISCOMA (Factory  
BP 3214 at Pout)  
DAKAR  
Senegal

Telephone: Pout 81096, 81136

Telex: 7781 SISCOMA SG

City Office: SISCOMA  
rue du Dr Theze/  
Grammont  
DAKAR  
Senegal

Telephone: 22375-84

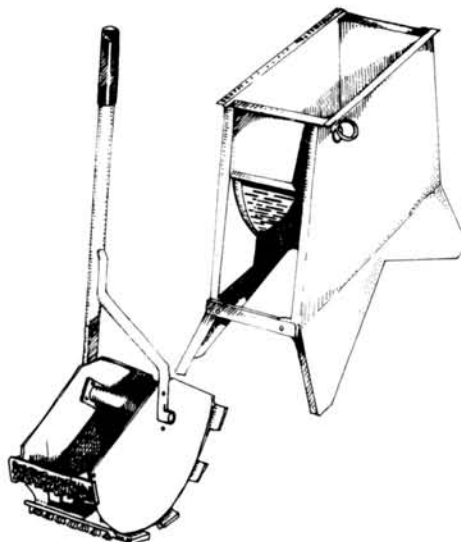

Description: The Siscoma alternating groundnut thresher is supplied with a set of interchangeable screens. Its potential capacity is 100kg. kernels/hour.

Price: (as at 1.1.80) 21,300 CFA (\$100.00)

## GROUNDNUT STRIPPER

### Manufactured by:

SISCOMA (Factory  
BP 3214 at Pout)  
DAKAR  
Senegal

Telephone: Pout 81096, 81136

Telex: 7781 SISCOMA SG

Description: The Siscoma groundnut stripper is particularly suitable for confectionery groundnuts. It is crank-driven and the axle is mounted on sealed bearings. Potential capacity is 200kg. pods/hr.



Price: (as at 1.1.80)

27,188 CFA (\$128.00)

---

(PRICES LATEST AVAILABLE FOR GUIDANCE ONLY. REFER MANUFACTURER FOR ACTUAL)

## OUEME WINNOWER

### Manufactured by:

SISCOMA (Factory  
BP 3214 at Pout)  
DAKAR  
Senegal

Telephone: Pout 81096, 81136

Telex: 7781 SISCOMA SG

City Office: SISCOMA  
rue du Dr Theze/  
Grammont  
DAKAR  
Senegal

Telephone: 22375-84

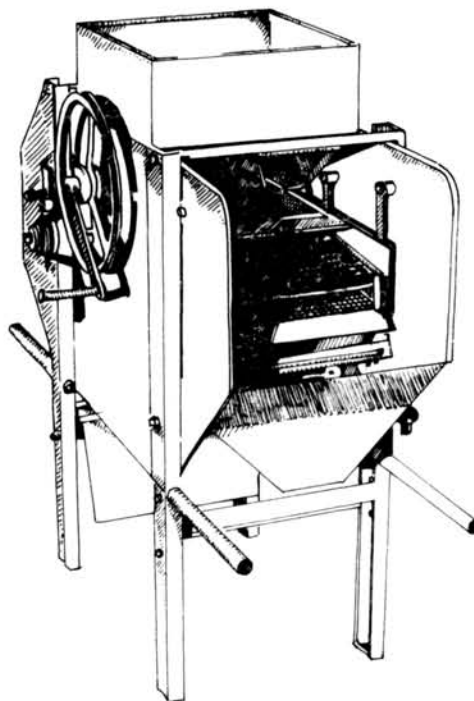

Description: The Oueme is designed for winnowing all types of cereal and is fitted with 3 separate winnowing screens. It can be operated by hand or by motor.

Price: (as at 1.1.80) 76,885 CFA (\$361.00)

## PADDY THRESHER

### Manufactured by:

SISCOMA (Factory  
BP 3214 at Pout)  
DAKAR  
Senegal

Telephone: Pout 81096, 81136

Telex: 7781 SISCOMA SG

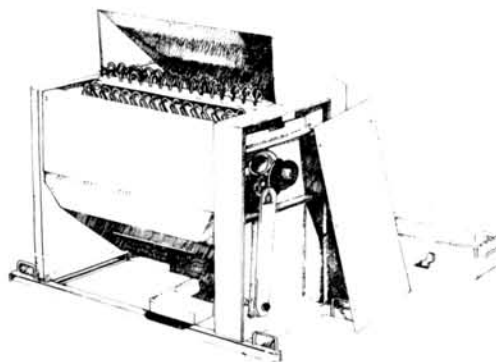

Description: There are 2 models of paddy thresher, both with the same drum and box, but one geared for pedal operation, the other for power take-off.

The threshing drum has a width of 80cm., and the hourly capacities are:-  
150kg./hr (pedal driven)  
250kg./hr (motor driven)

Price: (as at 1.1.80) For pedal operation 103,763 CFA (\$487.00)  
For power operation 166,432 CFA (\$781.00)

---

(PRICES LATEST AVAILABLE FOR GUIDANCE ONLY. REFER MANUFACTURER FOR ACTUAL)

PADDY THRESHER

Manufactured by:

Agrimal (Malawi) Ltd  
PO Box 143  
BLANTYRE  
Malawi

Telephone: Blantyre 30692, 31259

Telex: 4282 MI

Telegrams: AGRIMAL

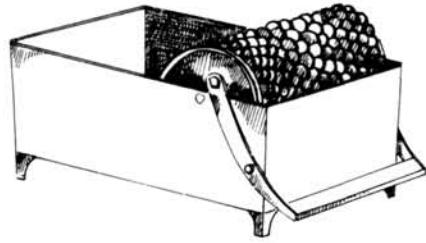

Description: The threshing drum is mounted in an oblong box and is operated by means of a foot treadle, allowing the operator to feed the sheaves of paddy by hand. The capacity of the thresher is about 200kg. of paddy per hour.

Price: (as at 1.4.80) 310 Kwacha (\$378.00)

PALM-NUT CRACKER

Manufactured by:

SISCOMA (Factory  
BP 3214 at Pout)  
DAKAR  
Senegal

Telephone: Pout 81096, 81136

Telex: 7781 SISCOMA SG

City Office: SISCOMA  
rue du Dr Theze/  
Grammont  
DAKAR  
Senegal

Telephone: 22375-84

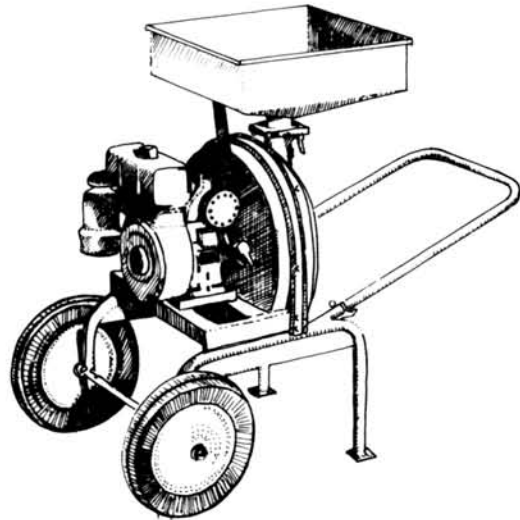

Description: The palm-nut cracker operates centrifugally, by means of a disc driven inside a drum by direct drive from a 3h.p. petrol engine. The hourly capacity of the cracker is 300-400kg/hr. (The motor is a Bernand W19A)

Price: (as at 1.1.80) 151,469 CFA (\$711.00)

---

(PRICES LATEST AVAILABLE FOR GUIDANCE ONLY. REFER MANUFACTURER FOR ACTUAL)

# GRINDING MILLS

## NDUME POWER DRIVEN HAMMER-MILLS

ND20, ND30 and GM40

### Manufactured by:

Ndume Ltd  
PO Box 62  
GILGIL  
Kenya

Telephone: Gilgil 223

Telex: 39801

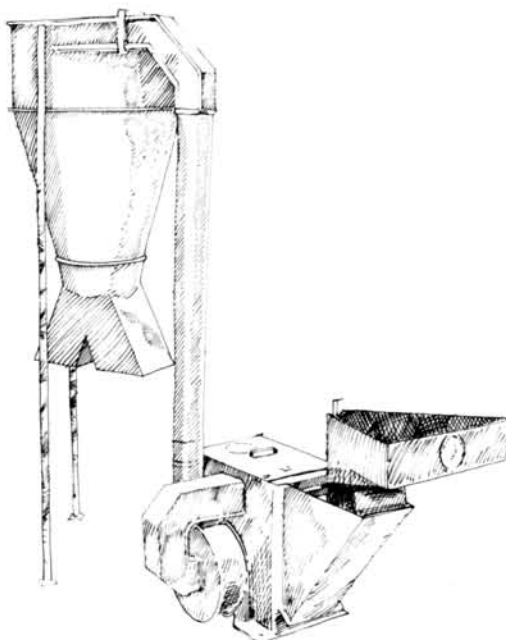

Description: The Ndume hammer-mills are designed to mill a variety of crops: maize, wheat, oats, barley, millet, hay and straw, but are especially suitable for grinding maize into meal. There are 3 models: the ND20, ND30 and GM40, of differing sizes but all of a similar basic design. From the loading hopper, grain is fed into the central mill housing in which heavy duty hammers grind the grain. The hammers are reversible, and replaceable. From the mill-housing, a fan blows the meal up into an overhead screened hopper.

The ND20 is the smallest model, the cheapest and with the lowest capacity and can be driven from small power sources of 12-25 HP. The ND30 is the next in size. It has double the capacity of the ND20, and it is fitted with a special overhead screen which allows oversize meal particles to fall back into the mill for regrinding. The meal it produces is therefore finer. The ND30 can be driven from small power sources of 16HP but also from larger sources up to 100HP. It is, of course, nearly twice the price of the ND20.

The GM40 is specially designed for power take-off from tractors, costing about the same and having about the same capacity as the ND30, but designed to operate at the lower r.p.m. given by tractor pulley-drive.

The price and approximate capacities of each mill, as quoted by the manufacturers, are shown below and the ND30 is illustrated.

### Prices and capacities: (as at 1.11.79)

Model	Price (retail)	Capacity/hour	Power source	HP
ND20	Kshg.5110.00 (\$ 684)	200-250kg. 450-550kg.	Lister ST1 Lister ST2	12-25 HP
ND30	Kshg.9480.00 (\$1269)	750-900kg. 900-950kg.	Lister HR2 Lister HR3	16-100HP
GM40	Kshg.9780.00 (\$1309)	900kg.	45HP Tractor	25-100HP

(PRICES LATEST AVAILABLE FOR GUIDANCE ONLY. REFER MANUFACTURER FOR ACTUAL)

## MANIK GRINDING MILLS

MGM2, MGM 5, MGM 7 and MGM 10

### Manufactured by:

Manik Engineers  
PO Box 1274  
ARUSHA  
Tanzania

Telephone: Arusha 3520

Description: Manik grinding mills are designed to mill a variety of crops but are especially useful for grinding maize. The mills are manufactured in 4 sizes: small, medium, standard and large. Construction of all models is from heavy welded steel, and the grinding mechanism is mounted on imported sealed bearing units. The hammers are reversible, and can be used on 4 different faces before replacement.

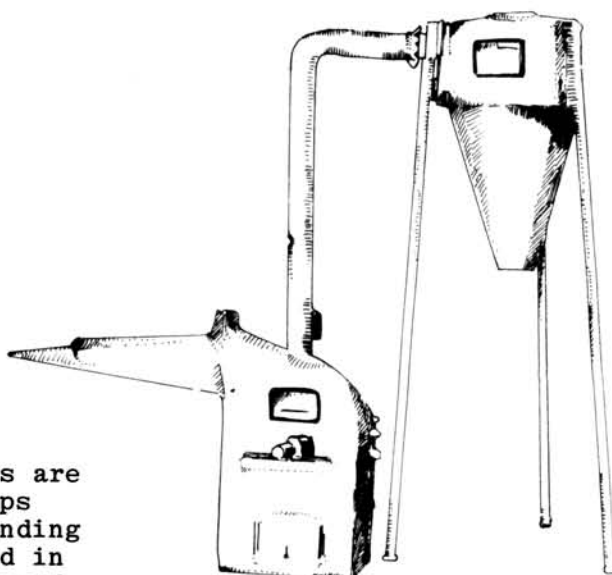

### Prices and capacities (Small, medium & large models):

<u>Model</u>	<u>Price (retail)</u>	<u>Capacity/hour</u>	<u>Power source</u>
MGM 2	Tshg.3000.00 (\$369)	90kg - 180kg	8-12HP
MGM 5	Tshg.4000.00 (\$492)	250kg - 640kg	15-40HP
MGM 10	Tshg.5600.00 (\$689)	550kg - 1100kg	30-60HP

## ATOM MAIZE MILL

Manufactured by: Brown & Clapperton  
PO Box 52  
BLANTYRE  
Malawi

Telephone: Blantyre 34677

Telex: 4243

Telegrams: BEANCE

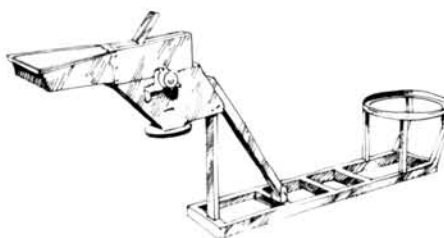

Descriptions: The Atom maize-mill is a small size hammer-mill designed to be powered by a 5-7HP diesel engine. It is fitted with reversible hammers, screens and sealed bearings. The average capacity is about 180kg per hour.

Price: (retail) (as at 1.7.80) 555 kwacha (\$677.00)

---

(PRICES LATEST AVAILABLE FOR GUIDANCE ONLY. REFER MANUFACTURER FOR ACTUAL)

UNITED MAIZE MILLS

NM 25, NM 50, NM 75, NM 100

Manufactured by:

United Engineering Works Ltd  
PO Box 3082  
ARUSHA  
Tanzania

Telephone: Arusha 3424

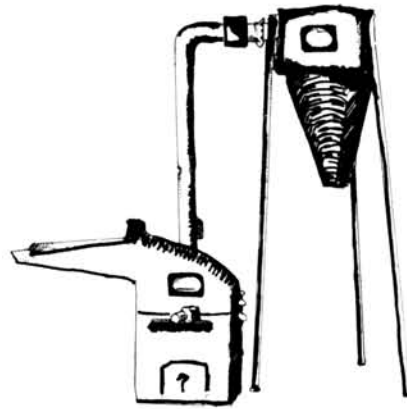

Description: United makes 4 sizes of hammer-mills with different capacities. The casing of each is made from durable heavy welded steel, inside which the steel shaft is mounted on scaled bearing units. The steel hammers are reversible and replaceable.

Prices and capacities: (as at 1.7.80)

<u>Model</u>	<u>Price (retail)</u>	<u>Capacity/hour</u>
NM 25	Tshg.1800.00 (\$221.00)	70kg - 270kg
NM 50	Tshg.2800.00 (\$345.00)	270kg - 600kg
NM 75	Tshg.3080.00 (\$380.00)	400kg - 900kg
NM 100	Tshg.3400.00 (\$420.00)	450kg - 1000kg

---

(PRICES LATEST AVAILABLE FOR GUIDANCE ONLY. REFER MANUFACTURER FOR ACTUAL)

## DUNIA HAND-OPERATED GRINDING MILL

### Manufactured by:

Ndume Ltd  
PO Box 62  
GILGIL  
Kenya

Telephone: Gilgil 223

Telex: 39801

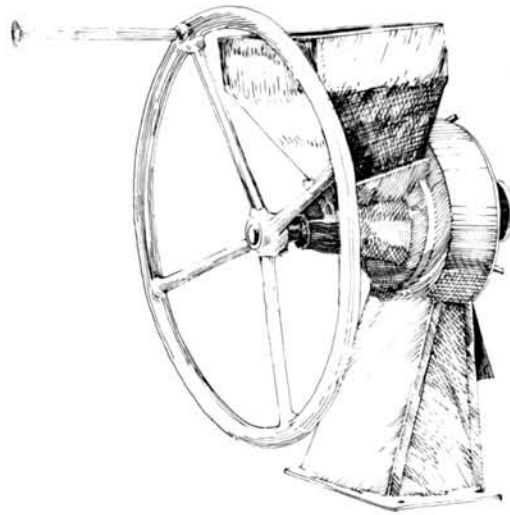

Description: The Dunia is a robust hand-operated mill that can be used for grinding many crops. Although principally designed for milling maize and wheat into flour, it can also be used to grind coffee.

No castings are used in the manufacture: it is all made from welded steel for durability. Cleaning the machine is relatively easy. The front cover can be removed by unscrewing wing-nuts and no spanners or special tools are needed for maintenance.

Using the Dunia, one man can grind about 20kg. of maize in one hour.

Price: (retail) (as at 1.11.79)

Kshg.880.00 (\$117.80)

## KUSINJA MAIZE-MILL

### Manufactured by:

Brown & Clapperton Ltd  
PO Box 52  
BLANTYRE  
Malawi

Telephone: Blantyre 34677

Telex: 4243

Telegrams: BEANCE

Description: The Kusingja Maize Mill is designed to be powered by diesel motors of between 10-20HP, and the milling capacity will vary according to the power source. With a 10HP motor, the capacity would be 150kg/hour, with a 20HP motor, 400kg/hour.

Price: (retail) (as at 1.7.80)

1050 kwacha (\$1280.00)

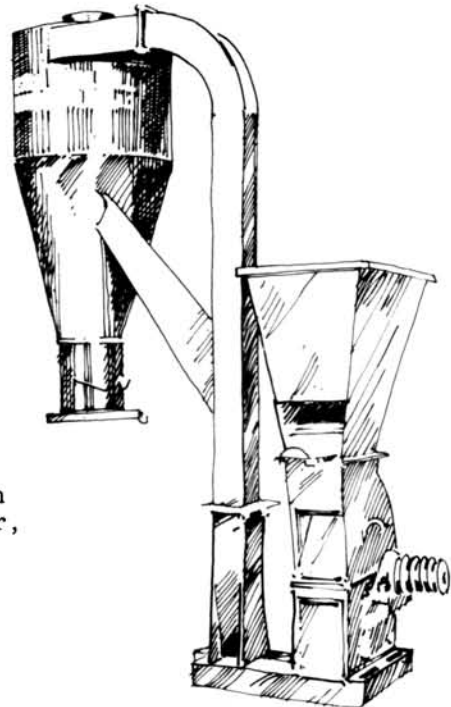

## RIIC SORGHUM DE-HULLER AND MILL

### Manufactured by:

Rural Industries Innovation Centre  
Private Bag 11  
KANYE  
Botswana

Telephone: Kanye 392/3

Description: In cooperation with the International Development Research Centre (IDRC) of Canada, RIIC at Kanye have developed a package of machinery that is of suitable scale for village operation in the making of sorghum flour.

The package consists of a de-huller and a hammer-mill and both are supplied together with extensive advice and operational brochure. The de-huller consists of a barrel-shaped container. The hammer-mill is of standard design, with interchangeable screens for different grades of flour.

Both can be powered with a single power source and whether petrol or diesel, it should be of a 24HP rating. The package of machinery is designed to operate either by batch method or continuous flow, and can thus be used either for milling individual lots or for commercial quantity milling.

Price: (ex-RIIC) (as at 1.1.80)

1. Sorghum de-huller, complete	1200 pula	(\$1519.00)
2. Hammer-mill, complete	850 pula	(\$1076.00)
3. Drive and pulleys	400 pula	(\$ 506.00)

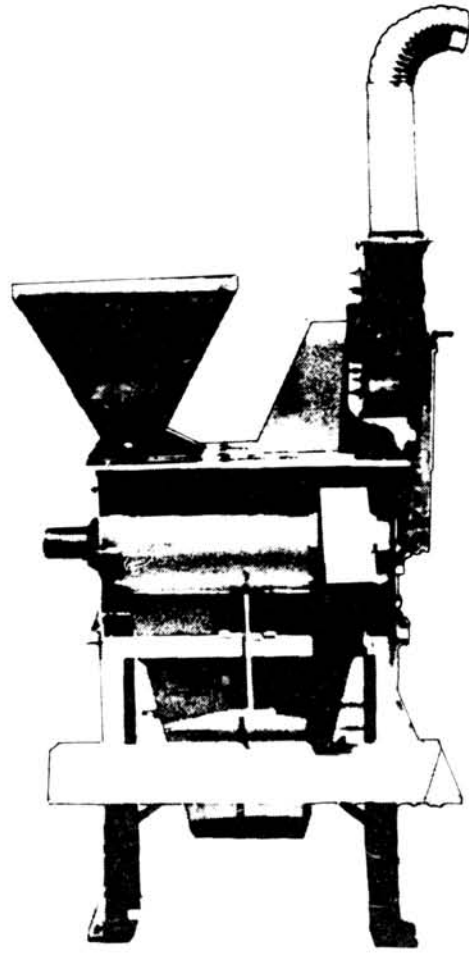

---

(PRICES LATEST AVAILABLE FOR GUIDANCE ONLY. REFER MANUFACTURER FOR ACTUAL)

# CROP STORAGE

## FERRUMBU MAIZE STORAGE BIN

### Designed by:

African Rural Storage Centre  
Mt Makulu Research Station  
PO Box 7  
CHILANGA  
Zambia

Telephone: Chilanga 315

Telegrams: Research, Chilanga

Description: The 'Ferrumbu' is a design of grain storage silo that is weather- and pest-proof and which can be made from commonly available materials - cement and chicken wire. The bin is built on a solid foundation of large stones, which acts as a damp-course; a cement floor and outlet spout are laid, and a wooden frame erected, around which is wrapped chicken-wire. Allowing for drying of the materials, a Ferrumbu bin can be built in 10 days.



It should be emphasised that this type of bin is designed for long-term storage, therefore fresh moist crops should not be stored until they have been dried. If they are, then moisture will encourage a high level of rotting.

Various sizes of bin can be built, and the cost of production depends on the size of bin. For example a 1.5 ton bin can be built with 4 bags of cement and 1 whole roll of 10 mm. chicken-wire.

### The approximate costs in terms of material:

0.75 ton capacity Ferrumbu - 3 bags of cement,  $\frac{1}{2}$  roll of chicken-wire

1.5 ton capacity Ferrumbu - 4 bags of cement, 1 roll of chicken-wire

---

(PRICES LATEST AVAILABLE FOR GUIDANCE ONLY. REFER MANUFACTURER FOR ACTUAL)

# PUMPING

## SHALLOW-WELL HAND-PUMP

### Developed by:

Department of Lands, Valuation  
& Water

Office of the President  
Private Bag 311  
Capital City  
LILONGWE 3  
Malawi

Telephone: 731-688/731-136

Telegrams: PRESMIN

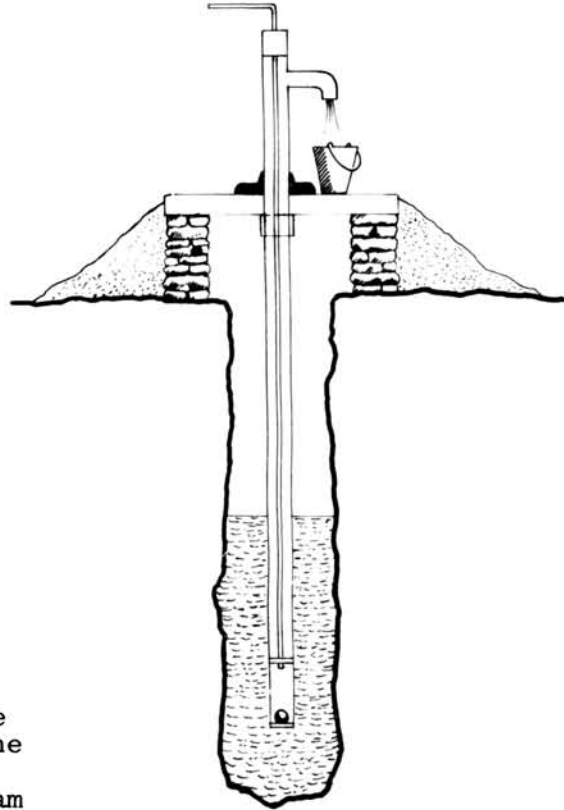

Description: The hand-pump is especially designed for a common site for groundwater supply in Malawi - the banks of 'dambos', which are shallow valleys in which, even when the stream is dry, groundwater is found near the surface.

The pump is designed to be mounted on a well platform at the edge of the dambo for all-season use, and is made from steel and PVC tubing components that are locally available. Its design has been chosen to enable its construction and maintenance to be relatively simple. Early models were made entirely from PVC piping which was technically quite adequate, however, the rising cost of petroleum-based plastics has now made steel tubing relatively cheaper and much of the pump-stand assembly is made from steel.

The shallow-well pump will eventually be installed in over 5000 villages in Malawi.

Price: (cost of production) (1980)

120 kwacha (\$140)

---

(PRICES LATEST AVAILABLE FOR GUIDANCE ONLY. REFER MANUFACTURER FOR ACTUAL)

## MAJENGO WATER PUMP

### Manufactured by:

Majengo Cooperative Group  
c/o Arusha Appropriate Technology  
Project  
PO Box 764  
ARUSHA  
Tanzania

Telephone: Arusha 3594

Telegrams: ATARU

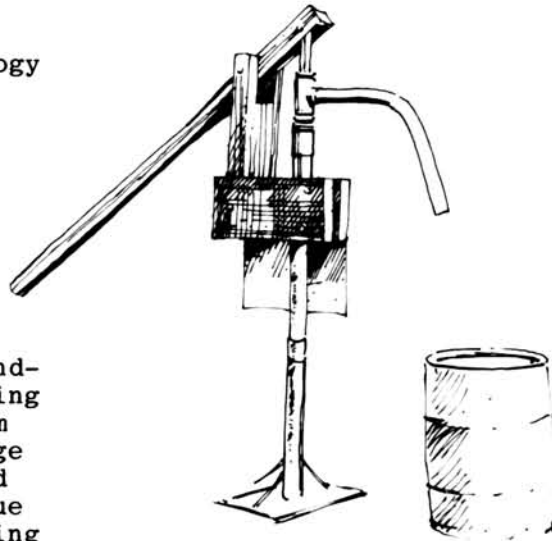

Description: The Majengo is a hand-operated single-action reciprocating piston pump for raising water from shallow wells, suitable for village water-supply, minor irrigation and cattle watering purposes. A unique feature of the design is a 'stuffing box' which enables water to be pumped under pressure to an overhead storage tank.

The pump handle is wooden, and all the metal materials used in the construction of the rest of the pump are locally obtainable in Tanzania. The pump has furthermore been designed so that construction requires no gas or electric welding, and it is offered by the Majengo Cooperative Group as a kit for assembly on site. The pump, although designed for manual operation, can also be adapted for engine or wind-power.

### Technical specifications:

Overall weight:	25 kg
Manual operative capacity:	1350 litres/hr (0.375 l/sec) from a 19 m. head

Price: (of kit) (as at 1.7.80)  
Tshg.1500.00 (\$184.50)

---

(PRICES LATEST AVAILABLE FOR GUIDANCE ONLY. REFER MANUFACTURER FOR ACTUAL)

## BORE-HOLE PUMPS

### Manufactured by:

Brown & Clapperton Ltd  
PO Box 52  
BLANTYRE  
Malawi

Telephone: Blantyre 34677

Telex: 4243

Telegrams: BEANCE

Description: Both models of the Brown & Clapperton Borehole Pump are manufactured from steel plate and pipes, and all pipe connections are galvanised. The pumps are designed for hand-operation on any shallow well up to a depth of 80 metres. Reference should be made to the manufacturers for details of the different specifications between Model 1 and Model 2.

Price: (as at 1.7.80)

Model 1	570 kwacha (\$695.00)
Model 2	640 kwacha (\$780.00)

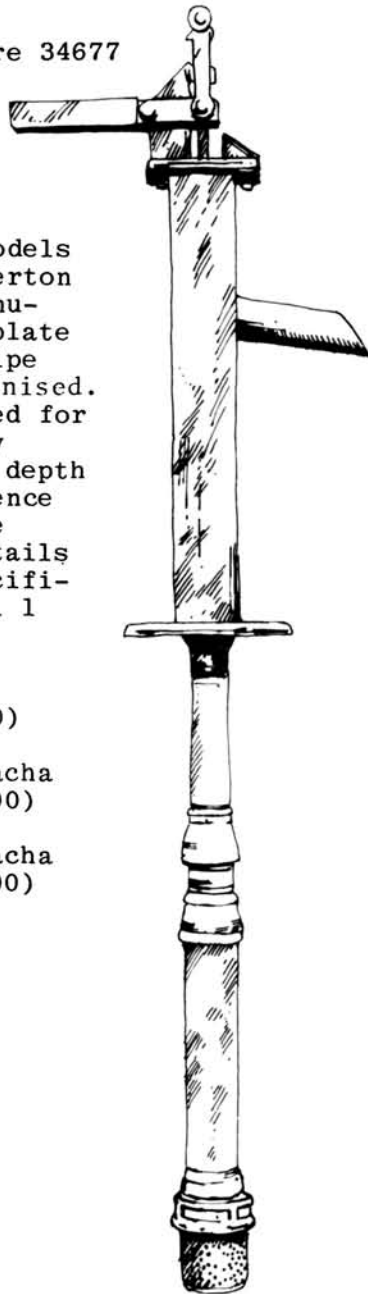

*Model 1.*

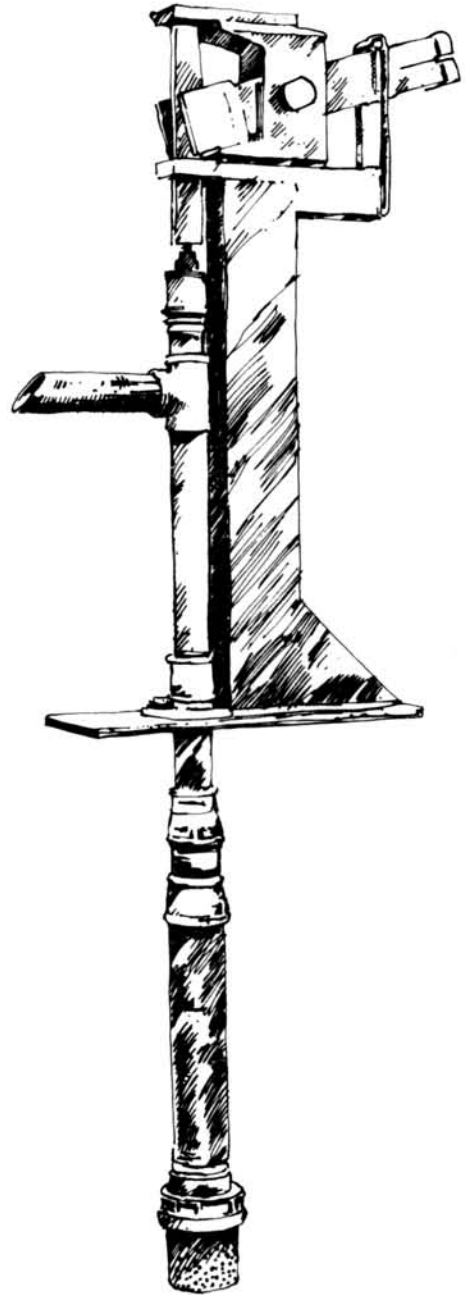

*Model 2.*

---

(PRICES LATEST AVAILABLE FOR GUIDANCE ONLY. REFER MANUFACTURER FOR ACTUAL)

## BRISAN PUMP

### Manufactured by:

Component Parts (Swaziland) Ltd  
Box 1087  
MBABANE  
Swaziland

(Factory at Manzini)

Telephone: Manzini 52900

Description: A compact water-pump designed to be fitted at the end of a PVC pipe and submersed in bore-holes for continuous pumping. The pump is electric powered and requires a mains-supply of 220-380 V(DC).

Submersible Franklin Electric motors are imported from the USA and attached to the pump unit which is made of plastic impeller rings manufactured in Swaziland. Different sizes of pumps (different power-ratings and lengths of pump unit) are made for differing lift requirements. The pump requires minimal servicing, as breakdown of the motor would mean replacement.

In a 400' bore-hole, the Brisan pump can lift 100 gallons/hour. Component Parts were manufacturing approximately 1000 units per year in 1979.

Price: (1980) 300 emalangenzi \$287.50



## GUEROULT BORE-HOLE PUMP

### Manufactured by:

SISCOMA (Factory at  
BP 3214 Pout)  
DAKAR  
Senegal

Telephone: Pout 81096, 81136

Telex: 7781 SISCOMA SG

Description: The Gueroult bore-hole pump can be powered in 3 ways: by beam, by pedal or by animal drive. The pump-body is submersible and is connected to the surface power source by cable-drive. It is possible to replace the piston assembly without extracting the piping.

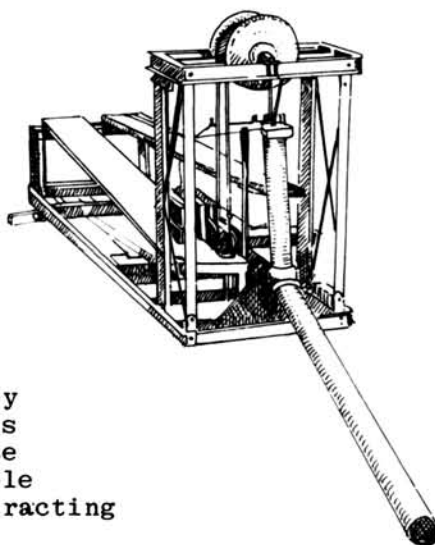

Performance: Lift potential: 10-60 m. (1 litre/sec -  
Output: 3600-80 litre/hr 0.2 litre/sec)

Price: 250,000 CFA (\$1174.00)

---

(PRICES LATEST AVAILABLE FOR GUIDANCE ONLY. REFER MANUFACTURER FOR ACTUAL)

## ARUSHA WINDMILL

### Manufactured by:

Ujuzi Leo Industries  
PO Box 7146  
ARUSHA  
Tanzania

Telephone: Arusha 3297

Description: The Arusha windmill is a 6 blade low-speed windmill built entirely of locally available raw materials capable of pumping 1 litre/sec in a 19km/hr wind, to a 55m delivery head. The sails are made of corrugated iron sheets, and the legs and pump shaft from tubular steel.



### Technical Specifications:

Tower height: 12.0m  
Rotor diameter: 5.03m  
Total wt. of Fan and Tail: 122.5kg  
Total overall weight: 360kg

### Static Torque (in 20 kph wind)

1355 Nm (1000 lbf)  
developing 2.2 kw at 24 kph

Price: (as at 1.7.80) Tshg.16,000.00 (\$1970.00)

---

(PRICES LATEST AVAILABLE FOR GUIDANCE ONLY. REFER MANUFACTURER FOR ACTUAL)

## PAP DRAGON WINDMILL WATER PUMP

### Manufactured by:

Ploughs & Allied Products Ltd  
PO Box 467  
KISUMU  
Kenya

Telephone: Kisumu 40512

Description: The PAP Dragon Windmill has entered production to a design developed in cooperation with UNDP. It is a 12 blade low speed pump lifting about 2 litres/secs in a 16km/hr wind, or 4 litres/sec in a 30km/hr wind. It is manufactured from locally available materials and has the following technical specifications:-

Tower Height	6m
Rotor Diameter	5m
Tower Base	2m x 2m
Max RPM	120
Suction Head	6m
Delivery Head	10m
Pump Diameter	15cm
Pump Stroke	24cm

It is fitted with a side vane safety system which operates at high wind speed. This is linked to a ratcheting tail-vane lock which ensures that the rotor will not turn again until re-set by the operator. The pump is made from PVC piping with a wooden piston and leather valves, reducing maintenance costs and ensuring a low torque on starting.

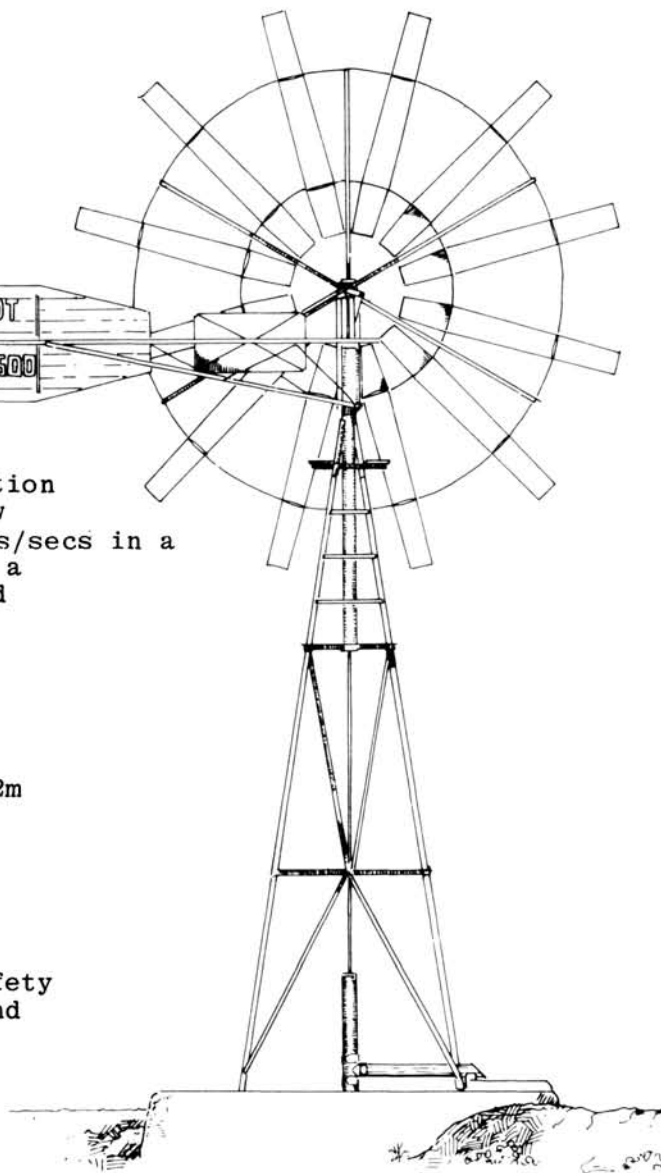

Price: (ex-factory) (as at 1.7.80)

Kshg.16,000.00 (\$2140.00)

---

(PRICES LATEST AVAILABLE FOR GUIDANCE ONLY. REFER MANUFACTURER FOR ACTUAL)

## KIJITO WINDMILL

### Manufactured by:

BobsHarries Engineering Ltd  
Karamaini Estate  
PO Box 40  
THIKA  
Kenya

Telephone: Thika 47234, 47250

Telex: 22776 SPECMOULD

Telegrams: BOBS THIKA

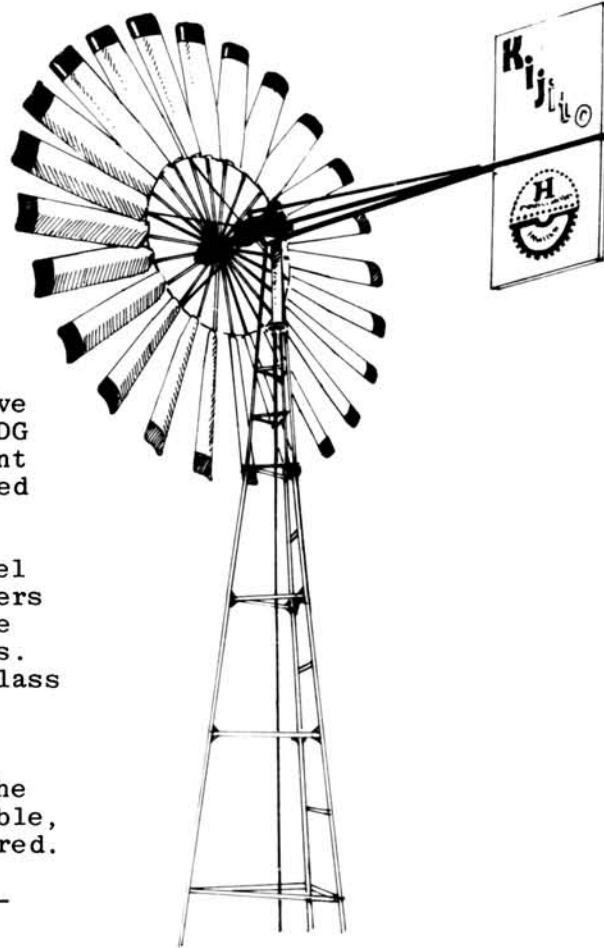

Description: Kijito windmills have been developed from a design by ITDG (Intermediate Technology Development Group) and are particularly designed for deep-bore-hole pumping.

Kijito windmills are made from steel plate mounted on tubular steel towers and the rotor hub is designed to be fitted with between 6 and 24 blades. The blades are moulded from fibreglass in order to maximise aero-dynamic efficiency.

The number of blades, as well as the diameter of the rotor can be variable, according to the performance required. Kijito windmills are supplied with rotors of the following diameters:-

3.7m., 4.9m., 6.1m. and 7.3m.

Kijito windmills are fitted with a self-governing safety mechanism which turns the rotor out of wind for wind-speeds over 40k.p.h. Performance depends upon the combination of rotor and water-pump but average performance of different rotor sizes, pumping from different depths is shown in the table:-

### Performance of Kijito Windmills at constant 12 k.p.h. wind-speed (litres per sec.)

		<u>Pumping Head</u>			
		30m.	60m.	120m.	240m.
<u>Rotor Diameter:</u>	3.9m.	0.60	0.30	0.15	-
	6.1m.	1.16	0.58	0.29	-
	7.3m.	2.01	1.01	0.50	0.25

### Prices: (as at 1.3.80)

	<u>Windmill</u>	<u>plus Installation</u>
3.9m rotor	Kshg.51,750.00 (\$6,900)	57,750.00 (\$ 7,700)
6.1m "	Kshg.69,000.00 (\$9,200)	76,500.00 (\$10,200)
7.3m "	Kshg.86,250.00 (\$11,500)	93,750.00 (\$12,500)

These prices include a 10m. tower; for larger towers an extra charge is levied, e.g. for a 20m. tower, the total cost would increase by Kshg.34,000 (\$4,500)

## JANDU HYDRAULIC RAM

### Manufactured by:

Jandu Plumbers Ltd  
PO Box 409  
ARUSHA  
Tanzania

Telephone: Arusha 3410, 3468

Telex: 42093 JAPCON

Description: Hydrams are designed to lift water for delivery to a relatively great height from a given driving water source whose fall may be relatively moderate. The Jandu Hydram will lift water according to the following relationship:-

$$q = Q \times h/H \times 4/5$$

where  $q$  = the flow delivered,  
 $Q$  = the flow of the source,  
 $h$  = the fall of the source and  
 $H$  = the delivery lift.

Thus a Hydram installed in a stream whose flow was 100 litres/minute, falling 5 metres, could lift water to a height of 40 metres with a delivery flow of 10 litres per minute.

Jandu make several sizes of Hydram to suit different conditions, and will supply appropriate Hydrams to these conditions if informed of the specific conditions such as the rate of flow of the source, its fall, and the lift required.

Price: (as at 1.1.80) (SJR 1.5) Tshg.3000.00 (\$370.00)

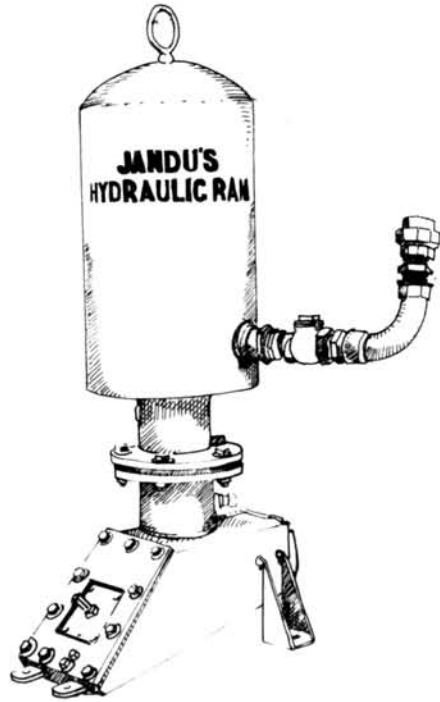

## JANDU PERSIAN-WHEEL

### Designed by:

Jandu Plumbers Ltd  
PO Box 409  
ARUSHA  
Tanzania

Description: Jandu Plumbers have designed and built a Persian wheel that is powered by a pair of oxen turning a rotor arm. As the use of ox-power for water-pumping is hardly developed in East Africa there is no effective demand for manufacture of Persian wheels. However, the company would be happy to discuss the likely cost of manufacturing Persian wheels to order, as well as supplying details of the likely performance.

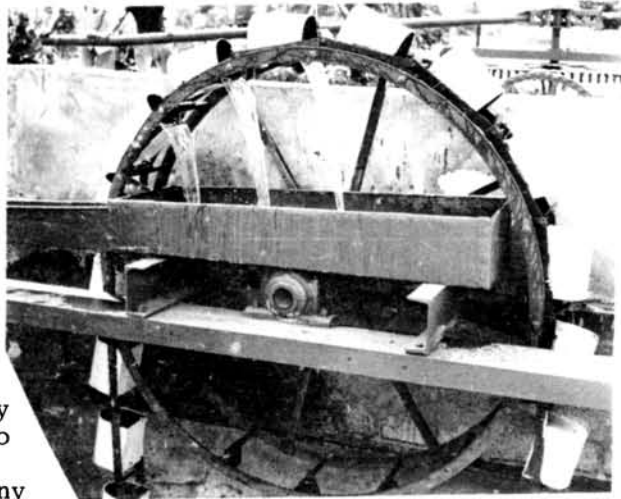

(PRICES LATEST AVAILABLE FOR GUIDANCE ONLY. REFER MANUFACTURER FOR ACTUAL)

## PRESSED STEEL WATER TANKS

### Manufactured by:

Warren Engineering Ltd  
PO Box 30151  
NAIROBI  
Kenya

Telephone: Nairobi 335671-5

Telex: 22032 Interlink

Description: Warren water tanks can be made in any size whose depth does not exceed 365 cm., by the assembly of standard pressed steel plates which measure 122 cm. square. The plates are supplied together with nuts and bolts and fixing strip, although the prices quoted below are just for the cost of steel plates required for different sizes of tank. The supporting structure and connecting plumbing-ware for the tank are not included but may be supplied separately.

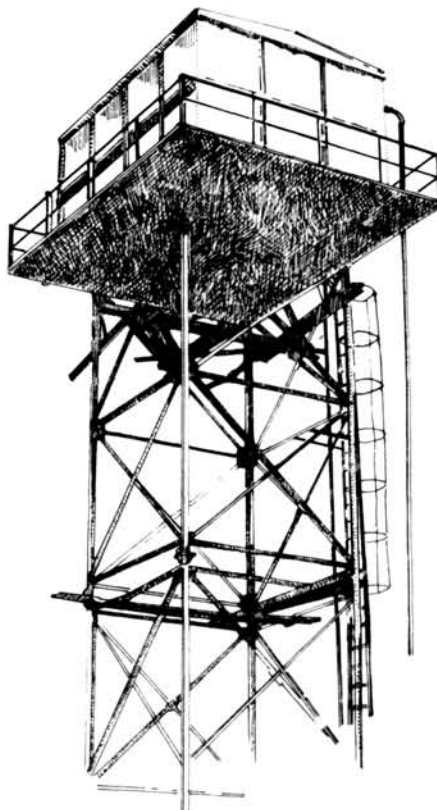

Price of steel plate components for different sized tanks: (as at 1.4.80)

<u>Size of tank</u>	<u>Price</u>	
1800 litres	Shg. 8,750.00	(\$1,170.00)
7200 litres	Shg. 24,500.00	(\$3,300.00)
14400 litres	Shg. 35,000.00	(\$4,700.00)

---

(PRICES LATEST AVAILABLE FOR GUIDANCE ONLY. REFER MANUFACTURER FOR ACTUAL)

# POWER

## HUTCHINSON METHANE PLANTS

### Manufactured By:

Tunnel Co. Ltd.  
Tunnel Estate  
FORT TERNAN  
Kenya

Telephone: Fort Ternan 7Y7

Description: There are two types of Hutchinson Methane Plant: the Continuous System Plant and the Batch System Plant. Various models of each have been developed at the Tunnel Company: some models are supplied in kit form, others are ready-to-use.

The Continuous System: operates on solid organic matter such as stalks, coffee pulp etc. and requires an inoculation of anaerobic bacteria. The manufacturers also recommend the purchase of an accompanying continuous plant, of at least the smallest size.

Batch System: Both plants, in addition to producing gas, also yield valuable organic manure as a residue and the manufacturers have observed that, for every twelve cows whose manure is used for methane production, one hectare of land can be fertilised with significant results. Of course, effective use of the continuous plants is very much dependent on the husbandry practiced and the ease of collecting the manure. Methane plants are more easy to use when cattle are gathered together at least once daily, as for milking.

As well as supplying the larger units in kit-form for the local market, the manufacturer is agreeable to licencing agreements with foreign manufacturers who are interested in the larger units. The smaller units which are supplied ready-made from the factory come with a two-ring gas cooker and a gas mantle-lamp ready for use.

The table shows the 1980 price and the output of each model, its type, and the recommended size according to the manure supply from varying herd sizes.

Model No.	System	Kit form/ Ready to use	Gas Output	Dairy Herd Size	Price (1980) Kshg. US
Mk.I	Batch	Kit form	2.5 m <sup>3</sup>	-	7000.00 (\$ 937)
Mk.II (Domestic)	Continuous	Kit form	12.8 m <sup>3</sup>	50	6000.00 (\$ 803)
Mk.II Large	Continuous	Kit form	21.5 m <sup>3</sup>	80	7000.00 (\$ 937)
Mk.II 2 Lid	Continuous	Kit form	43.0 m <sup>3</sup>	150	8000.00 (\$1071)
Mk.II 3 Lid	Continuous	Kit form	57.0 m <sup>3</sup>	200	9000.00 (\$1205)
Mk.III No.1	Continuous	Ready to use	0.7 m <sup>3</sup>	5	1760.00 (\$ 236)
Mk.III No.2	Continuous	Ready to use	1.4 m <sup>3</sup>	10	2500.00 (\$ 335)
Mk.III No.3	Continuous	Ready to use	2.1 m <sup>3</sup>	15	3630.00 (\$ 486)
Mk.III No.4	Continuous	Ready to use	2.8 m <sup>3</sup>	20	4235.00 (\$ 567)
Mk.III No.4 (Double)	Continuous	Ready to use	5.6 m <sup>3</sup>	40	7700.00 (\$1031)
Mk.IV	Batch	Ready to use	1.0 m <sup>3</sup>	-	2000.00 (\$ 268)

#### HUTCHISON SOLAR HOT-WATER UNITS

##### Manufactured by:

Tunnel Co Ltd  
Tunnel Estate  
FORT TERNAN  
Kenya

Telephone: Fort Ternan 7Y7

Description: These units heat water for domestic purposes. They are supplied as complete units of solar panels and insulated storage tanks. They can be obtained in various capacities, according to the number of standard sized panels in each unit. Each panel measures 300 cm x 70 cm.

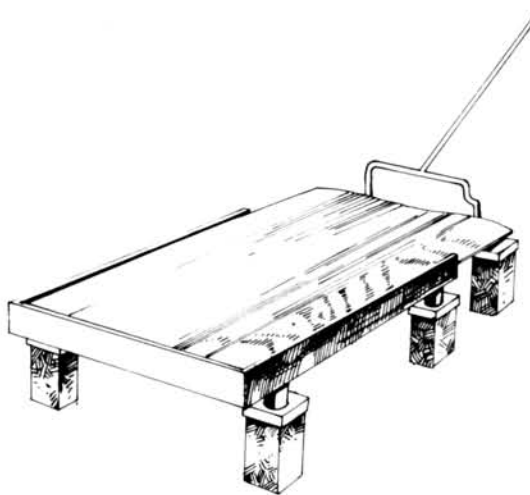

The manufacturers claim that normal daily insolation will heat water to 60°C, and that 40°C can be achieved in overcast conditions.

Corrugated steel absorber panels are used, coated with anti-corrodant, covered with u/v-resistant polyester envelopes whose durability is approximately 2-4 years. Spare covers can be obtained.

The prices and capacities of each available model are:

Model	Capacity	Price: Kshg.	US\$(as at 1.1.80)
SHWU No.1	45 litre	1815.00	243
SHWU No.2	90 litre	3025.00	405
SHWU No.3	135 litre	3630.00	486
SHWU No.4	180 litre	4840.00	648

(PRICES LATEST AVAILABLE FOR GUIDANCE ONLY. REFER MANUFACTURER FOR ACTUAL)

## METHANE GENERATOR

### Developed by:

Uhandisi Cooperative Society  
PO Box 849  
ARUSHA  
Tanzania

Telephone: Arusha 2625

### In conjunction with:

Arusha Appropriate Technology  
Project  
PO Box 764  
ARUSHA  
Tanzania

Telephone: 3594

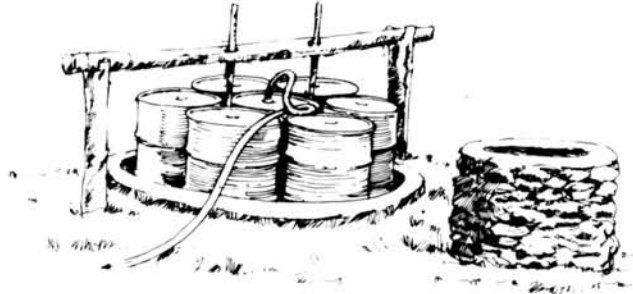

Description: The AATP have developed a methane generator made from seven 200 litre oil drums, whose tops are removed and are then inverted over a sunken pit into which cattle/chicken dung can be poured and mixed with water. Methane generated from this slurry rises into the drums and is piped off for storage in a simple gasometer before domestic use. The design is being used by Uhandisi for the manufacture of generators to local demand - made to order according to the size required.

Price: (as at 1.7.80)

Variable to size - from Tshg.1200.00 (\$150.00)

---

(PRICES LATEST AVAILABLE FOR GUIDANCE ONLY. REFER MANUFACTURER FOR ACTUAL)

# INCUBATOR, HONEY, MOHAIR

## KILACHA INCUBATOR

### Manufactured by:

Kilacha Production & Training  
Centre  
PO Box 21  
HIMO  
near Moshi  
Tanzania

Telephone: Himo 19

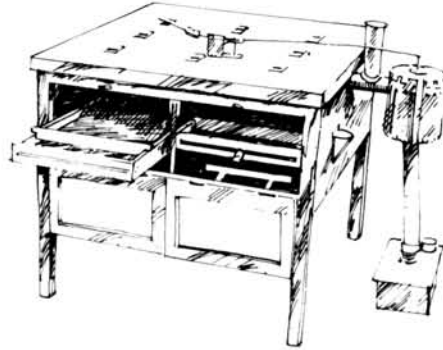

Description: The Kilacha Production & Training Centre is part of the Diocese of Moshi in Tanzania and the incubator has been designed to meet the needs of small farmers and small poultry production units whose only fuel source is kerosene. The incubators are fitted with kerosene burners, thermometers and thermostats and enable successful incubation of eggs. Seven sizes of incubator are made (to order) for capacities between 100-1000 eggs. Price varies with sizes, thus:

Price: (as at 1.6.80)

<u>Incubator capacity</u>		
100 eggs	Tshg.1700.00	(\$210.00)
200 "	Tshg.1900.00	(\$235.00)
300 "	Tshg.2200.00	(\$270.00)
400 "	Tshg.2500.00	(\$305.00)
500 "	Tshg.2800.00	(\$345.00)
600 "	Tshg.3000.00	(\$370.00)
1000 "	Tshg.5500.00	(\$675.00)

---

(PRICES LATEST AVAILABLE FOR GUIDANCE ONLY. REFER MANUFACTURER FOR ACTUAL)

## WOOL-MOHAIR SPINNING WHEEL

### Developed by:

CARE  
PO Box MS682  
MASERU  
Lesotho

Telephone: MS3982

### Manufactured by:

Save the Children Vocational  
Workshop  
PO Box MS286  
MASERU  
Lesotho

Telephone: MS2279

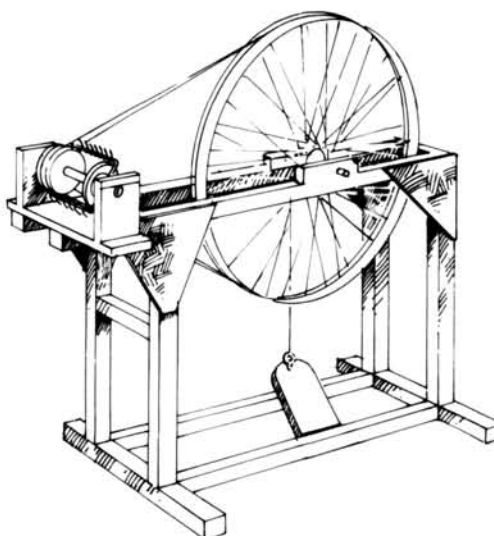

Description: A foot-treadle spinning wheel for spinning wool and mohair yarn. The fibre must first be carded carefully with carding combs. After carding, the fibre is ready for spinning, and after spinning it must be washed before being used for the manufacture of knit-wear.

Thus, although the spinning process alone can process 4 kg. of fibre per day, the whole process brings down production to about 4 kg. per month per wheel.

The wheel is constructed from a standard 26 in. bicycle wheel, and local timber. The bobbin-assembly is made from aluminium tube, hard-board discs, and medium gauge steel wire.

The spinning wheels are manufactured in the Save the Children Workshop which also manufactures carding combs.

<u>Price:</u> (1979)	Spinning Wheel	:	27 loti	(\$34.00)
	Carding Comb	:	15 loti	(\$19.00)

---

(PRICES LATEST AVAILABLE FOR GUIDANCE ONLY. REFER MANUFACTURER FOR ACTUAL)

## UNITED HONEY PRESS

### Manufactured by:

United Engineering Works Ltd  
PO Box 3082  
ARUSHA  
Tanzania

Telephone: Arusha 3424

Description: The honey press is a hand-operated screw-press which extracts honey from the honey-comb. It is made of metal, and could be used to extract up to 15 kg. of honey per hour from combs.

Price: (as at 1.6.80)

Tshg.285.00 (\$72.00)

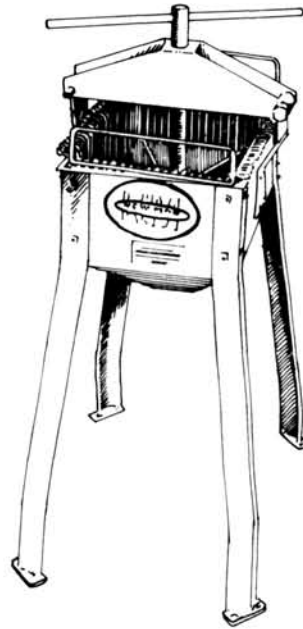

## TENGERU BEEHIVE

### Manufactured by:

Tengeru Furniture Mart  
PO Duluti  
ARUSHA  
Tanzania

Telephone: Duluti 41

Description: The Tengeru beehive is a top-bar hive made with 13 frames, spaced at 18 mm. apart. The box of the hive is made from a timber frame faced with chip-board and the outside is painted with a durable white paint. Each frame contains 3 longitudinal wires as comb supports. Replacement frames can be supplied, and super chambers are fitted.

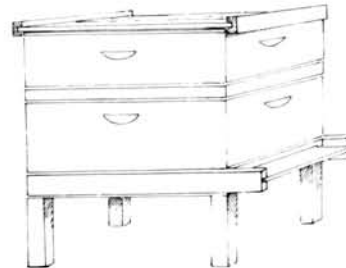

Prices: (1980) Tshg.240.00 (\$30.00)

---

(PRICES LATEST AVAILABLE FOR GUIDANCE ONLY. REFER MANUFACTURER FOR ACTUAL)

## BEEKEEPING EQUIPMENT

### Distributed by:

Beekeeping Section  
Ministry of Agriculture  
PO Box 30028  
NAIROBI  
Kenya

Telephone: Nairobi 48211

Description: The Beekeeping Section stocks beekeeping equipment some of which is made by the section, some of which by external contractors. The hive is the Kenya Top-Bar Hive, as illustrated, and the other equipment is listed in the price-list below:-

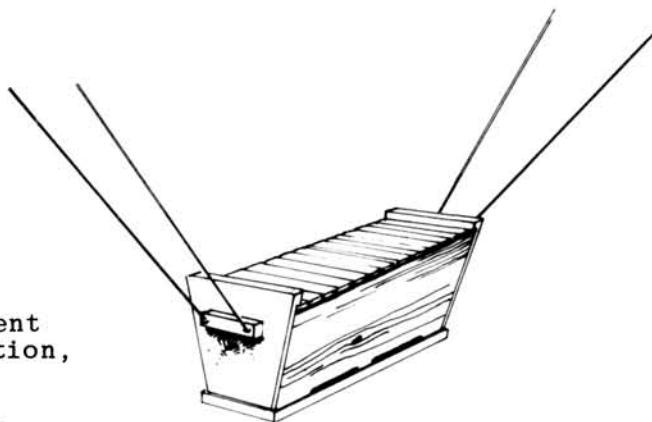

### Prices: (wholesale) (as at 1.7.80)

1. Kenya Top-Bar Hives	Kshg. 60.00	(\$ 8.00)
2. Catcher Boxes	Kshg. 30.00	(\$ 4.00)
3. Feeders	Kshg. 10.00	(\$ 1.35)
4. Queen Excluders	Kshg. 20.00	(\$ 2.70)
5. Smokers	Kshg. 35.00	(\$ 4.70)
6. Bee Brushes	Kshg. 12.00	(\$ 1.60)
7. Hive Tools	Kshg. 12.00	(\$ 1.60)
8. Gloves	Kshg. 25.00	(\$ 3.35)
9. Veils	Kshg. 20.00	(\$ 2.70)
10. Bee Suits	Kshg.100.00	(\$13.40)

---

(PRICES LATEST AVAILABLE FOR GUIDANCE ONLY. REFER MANUFACTURER FOR ACTUAL)

## BEEKEEPING EQUIPMENT

### Manufactured by:

John Rau & Co Ltd  
PO Box 2893  
SALISBURY  
Zimbabwe

Telephone: Salisbury 707682

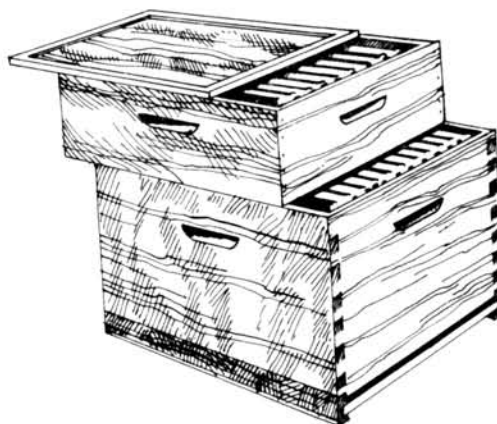

Description: Rau & Co manufacture and sell a complete range of bee-keeping equipment. Their hives, as illustrated, are made from timber planks, and are of Langstroth design, with brood and super chambers. The other equipment is listed below with prices.

### Prices: (ex-works) (as at 1.7.80)

1. Complete Hives	Zim\$25.00	(\$38.60)
2. Super Chamber only	Zim\$ 2.85	(\$ 4.40)
3. Frame (each)	Zim\$ 0.45	(\$ 0.70)
4. Queen Excluders	Zim\$ 3.30	(\$ 5.00)
5. Fire-Box Smokers	Zim\$13.75	(\$21.15)
6. Bee Brushes	Zim\$ 2.16	(\$ 3.30)
7. Uncapping Knives	Zim\$ 3.95	(\$ 6.00)
8. Hive Tools	Zim\$ 2.60	(\$ 4.00)
9. Gloves	Zim\$ 3.25	(\$ 5.00)
10. Veils complete	Zim\$17.00	(\$26.00)
11. Overalls	Zim\$ 8.20	(\$12.60)

---

(PRICES LATEST AVAILABLE FOR GUIDANCE ONLY. REFER MANUFACTURER FOR ACTUAL)



## OX-DRAWN BOWSER

### Manufactured by:

SISCOMA (Factory  
BP 3214 at Pout)  
DAKAR  
Senegal

Telephone: Pout 81096, 81136

Telex: 7781 SISCOMA SG

City Office: SISCOMA  
rue du Dr Theze/  
Grammont  
DAKAR  
Senegal

Telephone: 22375-84

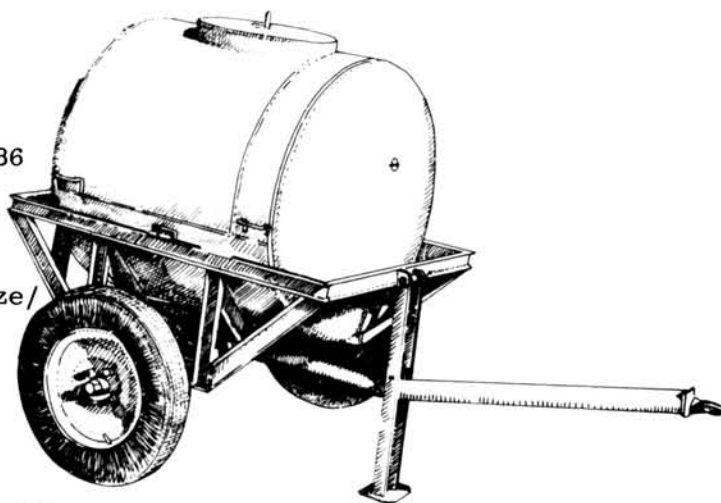

Description: The ox-drawn bowser has an unladen weight of 290kg. and a capacity of 800 litres (175 gallons).

Price: (as at 1.1.80) 236,900 CFA (\$1112.00)

## M'BAM DONKEY-CART

## MALAV HORSE-CART

### Manufactured by:

SISCOMA (Factory  
BP 3214 at Pout)  
DAKAR  
Senegal

Telephone: Pout 81096, 81136

Telex: 7781 SISCOMA SG

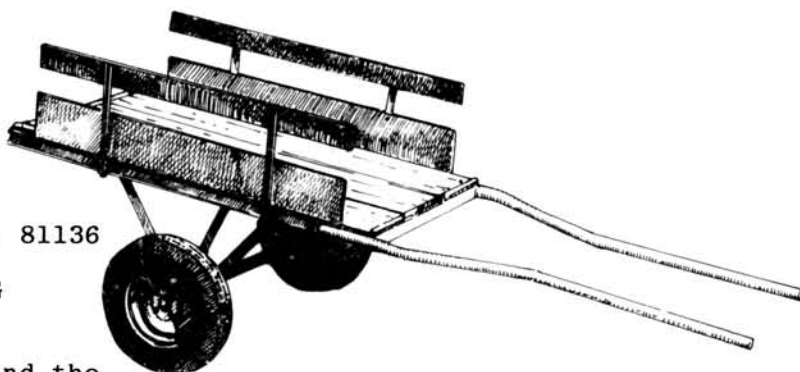

Description: The M'bam and the Malav are two simple carts, mounted on pneumatic-tyred wheels. The donkey cart has a  $\frac{1}{2}$  ton capacity, the horse-cart a 1 ton capacity.

The unladen weights are: M'bam - 108kg., Malav - 190kg.

Price:(as at 1.1.80) M'bam 54,900 CFA (\$258.00)  
Malav 67,700 CFA (\$318.00)

---

(PRICES LATEST AVAILABLE FOR GUIDANCE ONLY. REFER MANUFACTURER FOR ACTUAL)

## HEAVY DUTY OX-CART

### Manufactured by:

SISCOMA (Factory  
BP 3214 at Pout)  
DAKAR  
Senegal

Telephone: Pout 81096, 81136

Telex: 7781 SISCOMA SG

City Office: SISCOMA

DAKAR  
Senegal

Telephone: 22375-84

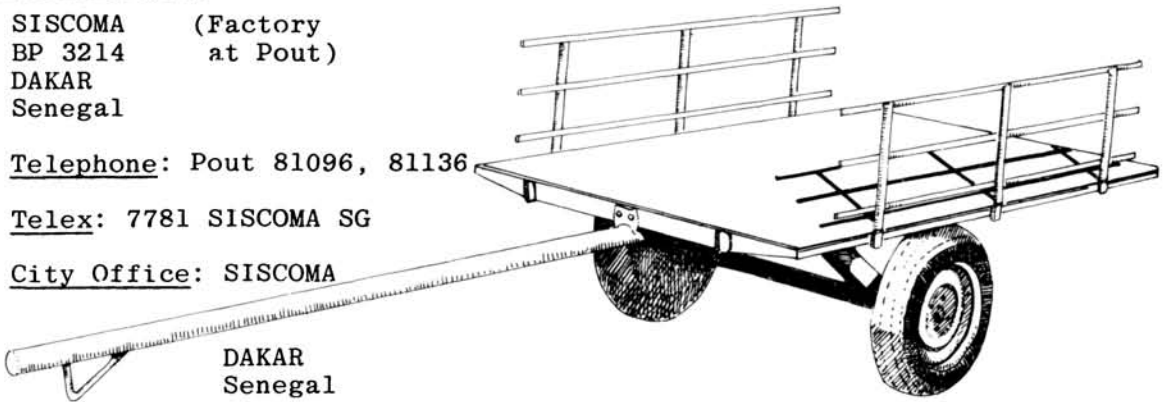

Description: The ox-cart, mounted on pneumatic tyres, has a capacity of 1.5 tons, with a low loader configuration.

Price: (complete) (as at 1.1.80)  
204,859 CFA (\$962.00)

## OX-CART

### Manufactured by:

Brown & Clapperton Ltd  
PO Box 52  
BLANTYRE  
Malawi

Telephone: Blantyre 34677

Telex: 4243

Telegrams: BEANCE

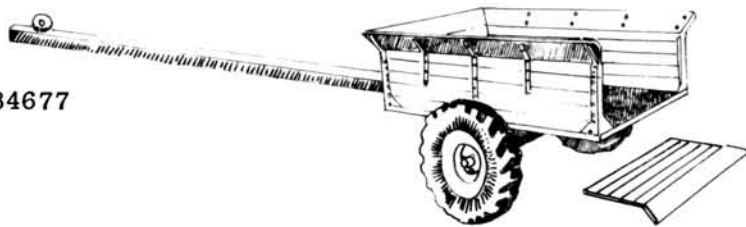

Description: The B&C ox-cart is a strong heavy-duty cart, mounted on a single axle fitted with treaded wheels. The front and rear panels of the body can be removed for taking long loads, and a specially designed 600 litre galvanized water tank is available as an extra.

Price: (as at 1.7.80) 528 kwacha (\$644.00)

---

(PRICES LATEST AVAILABLE FOR GUIDANCE ONLY. REFER MANUFACTURER FOR ACTUAL)

## NGOLO OX-CART

### Manufactured by:

Ngolo Industries  
LILONGWE

### Distributed by:

ADMARC  
P O Box 5052  
LIMBE  
Malawi

Telephone: Blantyre 651244

Telex: 4121

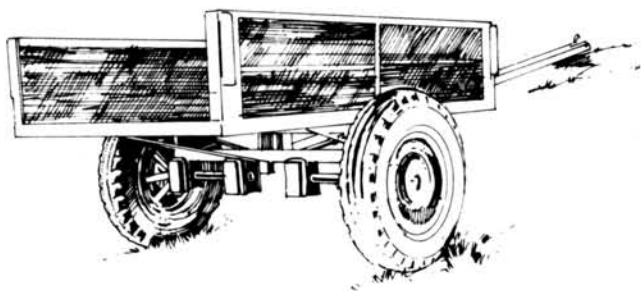

Description: A two-wheel ox-cart with a wooden body, and solid timber shaft. The wheels are fitted with pneumatic tyres and are mounted on a metal axle with sealed bearings.

Price: (Wholesale) (as at 1.1.80)

Kwacha 200.00 (\$244.00)

## WHEELS

### Manufactured by:

Ploughs & Allied Products Ltd  
P O Box 467  
KISUMU  
Kenya

Telephone: Kisumu 40512

Description: Pairs of metal-rimmed, spoked wheels suitable for ox-carts.

Price: (ex-works) (as at 1.7.80)

Kshg. 860.00 (\$115.00)

---

(PRICES LATEST AVAILABLE FOR GUIDANCE ONLY. REFER MANUFACTURER FOR ACTUAL)

4. COUNTRY GUIDES

# BOTSWANA

**Agriculture** With a population of only 700,000 and a land area of 580,000 square kilometres, Botswana is one of the least densely populated Commonwealth countries. However, much of the land is desert or semi-arid, suitable only for pastoralism, and even on the cultivable land the rainfall is not reliable. As the export of beef has become a major industry for Botswana (bringing in over US\$50 million per year), the improvement of livestock farming has as high a priority as the improvement of cropping techniques. The high level of livestock ownership and the need for extensive rather than intensive cropping in the arid climate have stimulated a particular interest in ox-drawn cultivation implements. The Makgonatsotlhe multi-purpose tool-bar has been developed to meet these needs, and is now being tested.

**Technology**

Botswana has recently established the Botswana Technology Centre, with a full-time director, and a governing board drawn from government ministries and from non-governmental organisations. The Centre will not do R&D itself, but will be a clearing house for information and ideas about appropriate technology.

**Existing patterns of trade**

Botswana is a member of the South African Customs Union, and most of its imports of agricultural equipment come either from or via South Africa, which also inevitably draws most Botswana exports. The opening of the border with Zimbabwe may change the pattern of trade routes. In 1978-79 a trial shipment of ten ox-drawn ploughs was sent from Dar-es-Salaam to Botswana, but their landed cost made them uncompetitive with the smaller SAFIM plough, imported from South Africa. Local production of equipment faces similar problems.

**Transport**

Not only relying on transit through South Africa for its own imports and exports, Botswana is also itself a transit country, for the railway from Zimbabwe to the southern ports of South Africa runs through Botswana. Botswana is also, to a small extent, a transit country for Zambian imports from South Africa, via the Kazungula ferry near Livingstone. Until 1976, when the border between Zimbabwe and Mozambique was closed, there was also rail traffic through Botswana to the port of Beira in Mozambique, and with Zimbabwe having attained independence this route should enable Botswana to reduce, to some extent, its present dependence on South African ports. In the longer term, there is the possibility of a railway being constructed to link Botswana with Walvis Bay in Namibia, which would make the exploitation of Botswana's mineral wealth easier. The railway through Botswana remains an important transit route for Zambia, Malawi and Zaire goods en route to or from South African ports.

This railway is currently run by Zimbabwe Railways, on behalf of the Botswana authorities, but control and management is being taken over by Botswana, as skilled manpower becomes available. It is planned to complete the takeover by 1985. The railway links up with the systems of Zimbabwe and South Africa, and carries most imports and exports to

and from Botswana. 65 -70% of freight is transit in normal years. The volume of road transport is small, except for the route from Francistown to Zambia via the Kazungula ferry, which is likely to decline.

In order to support its railways, South Africa restricts the use of road transport within its borders, so that trade between Botswana and Swaziland, and Botswana and Lesotho, is limited in scope and confined largely to the railway; goods to Swaziland go to Breyten, and are then taken into Swaziland by truck.

Some traffic from South Africa to Malawi has been taken via Botswana, the Kazungula ferry and Zambia, but this is unlikely to be repeated. A tarred road from Zimbabwe to South Africa through Botswana is expected to be completed in 1981.

Air Botswana flies scheduled flights to Johannesburg, Lusaka and Maseru. It does not operate a special cargo service, but freight can be carried on passenger flights, for a price.

Botzam Services and Jukes Curtis Transport, both in Francistown, are the only two road carriers of importance.

Agents

Manica Freight Services  
P O Box 1372  
Gaborone  
Tel. 71-293  
Telex 2256

Freight Factors Ltd  
P O Box 12  
Francistown  
Tel. 253  
Telex 2236

Manica Mann George  
P O Box 127  
Francistown  
Tel. 275  
Telex 2211

Transport Companies

Botzam Services  
Box 123  
Francistown

Zimbabwe Railways  
Box 494  
Gaborone

Carriers (Botswana)  
Box 231  
Francistown

Air Botswana  
Box 92  
Gaborone

Jukes Curtis Transport  
Box 436  
Francistown

Main features of Customs Regulations

1. With Lesotho and Swaziland, Botswana is a member of the South African Customs Union, with the Republic of South Africa.
2. The basis of valuation for duty is the 'normal price of the goods to the importer'. This is 'calculated on the basis of a sale thereof, at the time of entry for home consumption in the open market ... by any person to any other person both such persons being independent of each other ...'; it is in effect the FOB price.

3. Where both a percentage rate and a specific rate are shown, the higher is the operative rate.
4. A commercial invoice and bills of lading are required for all commercial consignments; the consignee usually stipulates the number of copies. Certificates of origin, the forms for which are available from commercial stationers, are required if preferential duty is to be claimed. No facsimile signatures are permitted.
5. An import surcharge of 7½% (on the normal price) is levied on goods imported, but with the following exceptions - plough shares, plough parts, harvesting machinery, combines, fodder presses and egg-grading machines.
6. Import licenses are required for all goods except those on a 'free-list' - this is signified in the tariffs below.

Customs Tariffs

CODE	ITEMS	TARIFF
82.01	Hand tools for agriculture, horticulture, or forestry	
82.01.10	Axes:+	
.10	Hatchets with steel handles	20%
.90	Others	3%
82.01.20	Grub hoes+	30%
82.01.30	Picks and mattocks	25% or 30¢ each
82.01.40	Forks:	
.10	Forks with 8 or more prongs	15%
.20	Grub forks	Free
.30	Others, with prong length exceeding 150mm	15% or 30¢ each
.90	Others	Free
82.01.90	Others (i.e. other hand tools)	Free
84.24	Agricultural and horticultural machinery for soil preparation or cultivation (for example ploughs, harrows etc)	
84.24.10	Ploughs, mouldboard type (excluding reversible type) with two or more but no more than 4 shares, designed for use with tractors	15%
84.24.15	Ploughs, disc type, with 2 or more but not more than 5 discs, designed for use with tractors	15%
84.24.50	Other ploughs	Free

84.24.55	Plough shares (angle & flat)*	20%
84.24.57	Plough discs	Free
84.24.60	Parts of ploughs (except disc and shares)*	15%
84.24.70	Harrows, offset disc type, of a width not exceeding 2m., designed for use with tractors	15%
84.24.75	Harrows, one-way disc type, of a width not exceeding 2.6m., designed for use with tractors	15%
84.24.80	Other harrows	Free
84.10.40.90	Reciprocating pumps driven by compression engines	20%
	Reciprocating pumps not driven by such engines	Free
84.10.50.10	Centrifugal, submersible, bore less than 200mm.	20%
83.24.87	Fertiliser distributors and manure spreaders	Free
84.24.90	Other agricultural or horticultural machinery for soil preparation or cultivation	Free
84.25	Harvesting and threshing machinery	
84.25.10	Harvesting and threshing machinery*	Free
84.25.15	Combines*	Free
84.25.20.10	Power-operated straw and fodder presses*	Free
.90	Other straw or fodder presses	Free
84.25.40	Hay or grass mowers (excluding lawn mowers)	Free
84.25.50	Winnowing and cleaning machines for seed, grain or leguminous vegetables	Free
84.25.80	Egg-grading machines*	Free

+ No import licence

\* No import surcharge

Source:

Customs Schedule, Department of Customs and Excise, Gaborone.

# KENYA

## Agriculture

Kenya has a population of over 14 million, about 90% of whom live in rural areas, most of them on smallholdings, though there are also large commercial farms and estates. The smallholding sector can be divided roughly into two parts, with smaller farms in high-potential areas growing cash crops such as coffee, tea, pyrethrum as well as subsistence crops, and larger farms on lower-potential land growing mainly subsistence crops. The average size of all small holdings is about 3.5 hectares, but this hides wide variations. Only 15% of Kenya's land area is fit for arable cropping, but there is great potential for irrigation. Much of the non-arable land is fit for pastoral grazing.

During the 1970s the small-holder sector contributed about 50% of marketed agricultural output, in addition to its subsistence production. The main food crop is maize, and the major cash crops coffee and tea, but cash-cropping is increasingly diversified, with fruit such as pineapples and mangoes being exported to Europe. Wheat is mainly grown on large commercial farms, but production is declining as such farms are subdivided. Agricultural produce accounted for about 45% of total export earnings in 1974.

The table below gives details of crop-production in 1976, broken down by 'large farm' and 'smallholder' sectors.

Crop Areas  
In Kenya,  
1976

	Large Farm ha.	Small- holders ha.	Total ha.
<u>Food Crops</u>			
<u>Cereals, pure stands</u>			
Hybrid maize	74,000	258,000	332,000
Local maize	n.a.	225,000	225,000
Finger millet	n.a.	31,000	31,000
Sorghum	n.a.	17,000	17,000
Wheat	89,000	20,000	109,000
Rice	n.a.	12,000	21,000
Other cereals	6,000	15,000	21,000
<u>Cereals, mixed stands</u>			
Local maize, beans etc	n.a.	634,000	634,000
Hybrid maize, beans etc	n.a.	243,000	243,000
Sorghum, beans etc	n.a.	98,000	98,000
<u>Other Crops, pure stands</u>			
Pulses	n.a.	70,000	70,000
English potatoes	2,000	49,000	51,000
Sweet potatoes	n.a.	11,000	11,000
Cassava	n.a.	41,000	41,000
Temporary crops	116,000	-	116,000
Fodder crops	8,000	n.a.	8,000
<u>Fruits &amp; Vegetables</u>			
Vegetables	2,000	4,000	6,000
Bananas	n.a.	20,000	20,000
Other fruits	n.a.	1,000	1,000

### Industrial Crops

Oil seeds	4,000	13,000	17,000
Sugar-Cane	30,000	55,000	85,000
Cotton, pure stands	n.a.	26,000	26,000
Cotton, mixed	n.a.	45,000	45,000
Barley	12,000	14,000	26,000
Other industrial crops	n.a.	3,000	3,000

### Export Crops

#### Pure Stands

Coffee	30,000	57,000	87,000
Tea	25,000	41,000	66,000
Pyrethrum	3,000	22,000	25,000
Sisal	77,000	n.a.	77,000
Pineapple	5,000	n.a.	5,000
Wattle	12,000	n.a.	12,000
Coconuts	2,000	2,000	4,000
Cashew	1,000	6,000	7,000
Other	3,000	23,000	26,000

#### Mixed

Coffee-banana-maize	n.a.	19,000	19,000
Coconut-cassava-maize	n.a.	49,000	49,000
Cashew-cassava-maize	n.a.	48,000	48,000

---

Total crop area (ha)	801,000	2,372,000	3,173,000
Double cropped area (ha)	n.a.	375,000	375,000
Net crop area (ha)	801,000	1,997,000	2,708,000

---

Source: Annual Reports, Ministry of Agriculture, Nairobi.

### Technology

Most Kenyan farmers use hand tools, the most common being the jembe (hoe) and panga (machete). These are mostly imported from a wide range of countries, but local manufacture is now starting. In 1976 there were an estimated 30,000 ox-drawn ploughs in use in the country, most of them also being imports, but local production of these is now more developed. Ox-ploughs are used for contract ploughing as well as on-farm work, so that in 1976 perhaps 10% of all smallholders had their fields ploughed by oxen. Forage is a problem in high-potential areas, where land is in short supply and dairy cows compete with draught animals. In 1976, there were also an estimated 10,000 ox-carts and 6,000 ox-drawn cultivators, as well as other animal-drawn equipment. Kenya imports about 1,000 tractors per year.

These are used on large farms and estates and also there are some tractor-hiring services operated by co-operatives and by private companies. Mouldboard ploughs are imported but most disc-ploughs are made locally, as are some disc harrows. Trailers are all locally manufactured.

In 1981 Kenya will have spent over 18 million shillings on an Intensive Agricultural Development Programme, part of which is to encourage the local manufacture of ox-drawn equipment and hand tools.

For some years there has been an Ad Hoc Committee on Agricultural Mechanization, and this formed the basis of a National Appropriate Technology Committee, which started work in 1978. Its members have been drawn from the main research organizations and concerned ministries, and it is charged with co-ordination and monitoring of technological developments in the country. It is now called the "Rural Development Technology Committee", and the Chairmanship is vested in the Ministry of Agriculture.

Kenya has a thriving private sector of equipment producers and innovators, and at Nakuru the Agricultural Machinery Testing Unit carries out standardised evaluations of local and imported equipment. For example, it has recently recommended one small tractor for importation, after testing eight similar models. The University's Department of Agricultural Engineering is also involved in R & D of agricultural equipment, as are a number of government and private organizations.

#### Transport

Kenya's border with Tanzania is closed so its only real trading link with the region is by sea via Mombasa. Mombasa is well served by ships going as far south as Nacala, less well by those going further south to Beira, Maputo and beyond.

Within Kenya the railway and road links are good, the rail connecting Mombasa with Nairobi and then on to Uganda. This line is heavily used. Kenya also acts as an import-and-transit country for Southern Sudan, Rwanda and Burundi, and to a lesser extent the eastern parts of Zaire. Road transport of goods to Sudan goes by the new Eldoret-Lodwar-Juba road.

Long-distance road freight is monopolised by the parastatal corporation, KENATCO.

#### Agents

Agence Maritime Internationale  
Box 18055  
Nairobi  
Tel. 555967  
Cable AGENMARIN  
Telex 22452

Kenya Shipping Agency  
Box 84331  
Mombasa  
Tel. 20501  
Cable MIZIGO  
Telex 21288

United Africa Corporation  
Box 47880  
Nairobi  
Tel. 23173  
Cable UNIAFRICA  
Telex 2260A/B

Dodwell & Co. E. Africa  
Box 30087  
Nairobi  
Cable DODWEL  
Telex (Mombasa) 21278

Leslie & Anderson, E. Africa  
Box 41132  
Nairobi  
Tel. 331722  
Cable Leslander

Nakufreight  
Box 41423  
Nairobi  
Tel. 332299  
Telex 22191

Kenya Transit & Trading Co.  
Box 91092  
Mombasa  
Telex 21203

Transport  
Companies

KENATCO Transport Co.  
Box 46991  
Nairobi  
Telex 22100

Schenker & Co. (EA)  
Box 46757  
Nairobi  
Tel. 25372  
Cable SCHENKERCO  
Telex 22277

Main features  
of customs  
regulations

1. No preferences.
2. Duty is assessed on the cost and freight value of the goods.
3. A Sales Tax is levied on the duty and tax-paid value of most goods. With the exceptions of hand tools, equipment listed in this guide carries a 15% sales tax.
4. All goods imported into Kenya must be insured by Kenya insurers.
5. Certain goods may only be imported on behalf of a government monopoly, the National Trading Corporation. This applies to hoes, jembes, machetes, pangas, axes, all types of fork, spades and shovels.
6. Foreign Exchange Allocation Licenses are required for all goods, except where CIF value does not exceed Kshg. 4,000, and except for certain capital goods foreign exchange is restricted, and only given according to certain quotas and for certain items.
7. Import licenses are required for certain goods, others may be imported under Open General Licence. Hand tools require a specific import licence, but foreign exchange will be granted automatically for their import. Other equipment in this guide may be restricted.
8. All goods imported into Kenya must be inspected before shipment, except:
  - (a) where value is less than Kshg. 20,000, unless in part shipments,
  - (b) goods purchased by the Kenya government,
  - (c) and other categories, not of interest to this guide.

9. Since December 1978 all imports have required a 100% refundable deposit with the Central Bank, except
- (a) raw materials and spare parts for agricultural and industrial machinery, for which the Bank requires only details of quantity and value within three months of import,
  - (b) certain goods, especially machinery, financed by foreign credits of 18 months or more.
10. 2 copies of an ordinary commercial invoice will normally be accepted in support of entry declarations, provided the invoice has an original signature; but import licence applications must be accompanied by at least 4 copies of pro forma invoices, and they must be accompanied by the appropriate form indicating that insurance is to be paid through a Kenyan company. Importers of machinery for production and manufacturing must also first clear their application with the New Projects Committee of the Ministry of Commerce & Industry.

Customs Tariffs

CODE	ITEM	TARIFF
82.01.000	Spades, shovels, picks, hoes, forks, rakes, axes, billhooks and similar hewing tools, scythes, sickles, hay knives, grass shears, timber wedges, and other tools of a kind used in agriculture, horticulture or forestry	20%
82.03	Saws, non-mechanical, and saw blades	30%
84.10.010	Pumps	Free
84.24	Agricultural and horticultural machinery for soil preparation or cultivation, including ploughs, seeders, planters, transplanters, fertiliser distributors, manure spreaders, scarifiers, cultivators, weeders, hoes and harrows (other than hand tools), and other such machinery and its parts (except for 84.24.049 below)	Free
84.24.049 - 84.24.059	Lawn and sports ground rollers and parts	10%
84.25	Harvesting and threshing machinery, straw and fodder presses, hay or grass mowers, winnowing and similar cleaning machines for seed, grain or leguminous vegetables, egg-grading and other grading machines for agricultural produce (other than those of a kind used in bread grain milling industry), including combine harvester-threshers, and parts for the above	Free
84.26	Dairy machinery, including milking machines and parts	Free

84.27	Presses, crushers and like machinery used in cider-making, wine-making, fruit juice preparation, and parts thereof	10%
84.28	Other agricultural and horticultural, poultry-keeping, and beekeeping machinery, germination plant fitted with mechanical or thermal equipment, poultry incubators and brooders	Free
84.28.011	Plate mills and hammer mills	15%
84.29	Machinery of a kind used in the bread grain milling industry, and other machinery (other than farm-type machinery) for the working of cereals or dried leguminous vegetables, and parts thereof	10%
84.30	Other machinery, e.g. tea and sugar processing	10%

Source: Kenya Dept. of Customs and Excise, Nairobi.

# LESOTHO

**Agriculture** Lesotho has a population of about 1.2 million, which makes it one of the most densely populated countries in the region, as its area is only 30,000 square miles. 50% of the male work force is absent at any one time, working in South Africa; Lesotho is completely surrounded by South Africa, and is a member of a common customs union with South Africa, Botswana and Swaziland.

The average size of holding is about 2 hectares. Much of the land is unsuitable for farming, being mountainous; soil erosion on slopes is a particular problem. Only 13% of the land area is cultivated, mostly on the 200,000 smallholdings. The great majority of these farmers use draught animals for ploughing, this type of mechanisation being well advanced in Lesotho.

## 1977-78, Area & Production of Major Crops

Crops	Area planted (hectares) in		Production (tons)
	Summer	Winter	
Fallow	63,161	271,583	-
Wheat	26,552	16,054	57,906
Peas	4,498	1,213	4,427
Maize	111,530	none	143,168
Sorghum	62,033	none	85,775
Beans	14,271	none	10,783
Others	4,154	97	Not available

Source: Annual Report, Ministry of Agriculture

## No. of farm households reporting use and ownership of sources of agricultural power, Lesotho, 1970

Holding size (acres)	No. of households	Draught animals			Tractors		
		Owned	Borrowed	Hired	Owned	Borrowed	Hired
No land	2,345	-	-	-	-	-	-
Under 2.0	36,792	7,367	8,181	16,724	126	41	1,399
2.0 - 3.9	55,689	15,438	10,305	25,370	35	-	2,168
4.0 - 5.9	40,849	14,025	6,193	16,010	225	55	1,725
6.0 - 7.9	22,282	9,633	3,143	6,832	-	-	1,531
8.0 - 9.9	13,277	6,172	2,068	4,311	229	-	405
10.0 - 14.9	11,584	5,571	1,086	4,010	55	-	1,046
15.0 & over	4,603	3,009	386	655	66	-	480

Source: 'Agricultural Equipment in Lesotho' T.E. Cobbald, ITDG, London 1976.



to be claimed. No facsimile signatures are permitted.

5. An import surcharge of 7½% (on normal price) is levied on goods imported, but with the following exceptions - plough shares, plough parts, harvesting machinery, combines, fodder presses and egg-grading machines. The tariff rate on these is shown in the table below.
6. Import licenses are required for all goods except those on a 'free-list' - this is signified in the tariffs below.

#### Customs Tariffs

CODE	ITEM	TARIFF
82.01	Hand tools for agriculture, horticulture, or forestry	
82.01.10	Axes:+	
.10	Hatchets with steel handles	20%
.90	Others	3%
82.01.20	Grub hoes+	30%
82.01.30	Picks and mattocks	25% or 30¢ each
82.01.40	Forks:	
.10	Forks with 8 or more prongs	15%
.20	Grub forks	Free
.30	Others, with prong length exceeding 150mm	15% or 30¢ each
.90	Others	Free
82.01.90	Others (i.e. other hand tools)	Free
84.24	Agricultural and horticultural machinery for soil preparation or cultivation (for example ploughs, harrows etc):	
84.24.10	Ploughs, mouldboard type (excluding reversible type) with two or more but no more than 4 shares, designed for use with tractors	15%
84.24.15	Ploughs, disc type, with 2 or more but not more than 5 discs, designed for use with tractors	15%
84.24.50	Other ploughs	Free
84.24.55	Ploughs shares (angle & flat)*	20%
84.24.57	Plough discs	Free
84.24.60	Parts of ploughs (except disc and shares)*	15%
84.24.70	Harrows, offset disc type, of a width not exceeding 2m., designed for use with tractors	15%
84.24.75	Harrows, one-way disc type, of a width not exceeding 2.6m., designed for use with tractors	15%

CODE	ITEM	TARIFF
84.24.80	Other harrows	Free
84.10.40.90	Reciprocating pumps driven by compression engines Reciprocating pumps not driven by such engines	15% Free
84.10.50.10	Centrifugal, submersible pumps bore less than 200mm	20%
84.24.87	Fertiliser distributors and manure spreaders	Free
84.24.90	Other agricultural or horticultural machinery for soil preparation or cultivation	Free
84.25	Harvesting and threshing machinery:	
84.25.10	Harvesting and threshing machinery*	Free
84.25.15	Combine harvesters*	Free
84.25.20.10	Power-operated straw and fodder presses*	Free
.90	Other straw or fodder presses	Free
84.25.40	Hay or grass mowers (excluding lawn mowers)	Free
84.25.50	Winnowing and cleaning machines for seed, grain or leguminous vegetables	Free
84.25.80	Egg-grading machines*	Free

+ No import licence

\* No import surcharge

Source: Customs and Excise Department, Maseru.

# MALAWI

Agriculture Malawi has a population of about 5.2 million, and around 4 million acres under cultivation; perhaps 1 million acres of good cultivable land remains uncultivated at present. About 5% of the land cultivated is under estates, of which there are about 400. Maize is the main crop, occupying 78% of the acreage under cultivation. Up-to-date figures are not available, but the distribution of principal crops in 1968/69 is shown in the table below.

Area under principal crops, and share of output by sector, Malawi, 1968/69. (Includes mixed cropping)

Crops	Acres '000	% of output grown on farms of less than 25 acres
Maize	2,643	87
Sorghum & Millets	1,226	)
Pulses	1,188	)
Groundnuts	1,100	) Not ) Available
Cassava	738	)
Potatoes	446	)
Tobacco	152	38
Cotton	91	100
Tea	43	6
Rice	41	100
Sugarcane	24	0

Source: National Sample Survey of Agriculture, 1968/9, Malawi Government.

Technology Most cultivation is still done by hand, using a tanged hoe, and most crops are grown on ridges. Ox-drawn implements were first introduced in the 1950s, and by 1969 there were 15,000 ox-drawn ploughs in the country, as well as 11,500 ox-drawn carts. Since then, there has been a considerable increase in the use of ox-drawn equipment. One constraint is a general shortage of draught animals.

The government considers that use of ox-drawn equipment is only viable on holdings of 8 acres or more. These make up about 120,000 of the 1 million smallholdings in the country. Another widely-used item of equipment is the knapsack sprayer; cotton and tobacco are both grown extensively by smallholders, and these crops require regular spraying. In 1969 there were 11,000 sprayers, most of them individually owned. Apart from some limited tractor-hire schemes, government policy is against pooling or communal use of equipment.

Mechanization policy is aimed particularly at four bottlenecks:- land preparation, when yield can be greatly increased by early planting; maize-shelling; groundnut shelling; and rice-threshing. Over 100 ox-training centres now operate, and evaluation and local manufacture of equipment to meet these bottlenecks is a priority.

Malawi imports relatively few hand-tools and little ox-drawn equipment. Agrimal (Malawi) Ltd., 80% locally-owned, manufactures enough of the following to meet local demand: hoes, ploughs, single-row planters with fertiliser attachment, cultivators, groundnut lifters, groundnut shellers and harrows. As can be seen from the table below, Agrimal also exports large quantities of equipment, mainly to Zambia. Other manufacturers in Malawi produce trailers, bore-hole pumps, maize-shellers and ox-carts. All tractors and tractor-drawn implements are imported, mainly from South Africa, the United Kingdom, Italy and Australia.

In 1978 a National Appropriate Technology Committee was established, under the umbrella of the National Research Council, the Secretary of which is the Co-ordinator of the NATC. Membership is drawn from the government, statutory bodies and from the private sector. Malawi has not set up a specialist AT Centre, feeling that there is enough productive work to be done in simply co-ordinating the existing R & D, manufacturing and extension services. The Chitedze Investigation and Testing Unit, which evaluates local and imported equipment, also develops equipment itself. Evaluation of sprayers is done by the Makola Research Station, and Bunda College of Agriculture evaluates machinery in the Agricultural Engineering Department.

Ownership of selected items, Malawi, 1969

Hoes	2,473,000	Pangas (machetes)	430,700
Axes	882,100	Ox-carts	11,500
Ox-ploughs	14,900	Sprayers	10,600
Work oxen	41,200		

Source: ibid.

Production & Exports of Agricultural Equipment, Malawi, 1977

Item	Production	Export
Hoes	711,000	74,000
Mouldboard ploughs	2,200	227 (1979, 2,665)
Ridging ploughs	2,000	1,000 (1979, 400)
Cultivators	350	239 (1979, 420)
Harrows	920	675 (1979, 100)
Planters	40	)
Maize mills	500	)
Borehole pumps	900	)
Ox-carts	480	) Not Available
Tobacco pressers	600	)
Maize sheller	1,000	)
Trailers	230	)

Source: Malawi country paper, Rural Technology Meeting, Arusha, 1977.

Transport

Malawi is land-locked, but has a direct rail link to the Mozambique ports of Nacala and Beira; the former carried 259,000 tons of Malawi traffic and the latter 581,000 tons in 1977. Both ports have container services. The railhead inside Malawi used to be at Salima, near Lake Malawi, but the line is now extended to the capital Lilongwe, and by 1981 a further extension through Mchinji to the Zambian border should also be completed. Malawi carries on extensive trade with countries to north and south, exporting the Agrimal implements to Zambia and Kenya among other countries.

There is a road link with Tanzania, via Katumbi and Tunduma through northern Zambia. Goods from Malawi to Zambia go by road via Chipata and Mchinji; there is also road traffic through Zambia to and from Botswana and South Africa.

Malawi has recently acquired the first container terminal of any land-locked country in Africa, at Blantyre, where containers arriving by rail from the ports can be re-routed by road to their final destinations.

Agents

Agence Maritime International  
P O Box 838  
Blantyre

Tel. 636066  
Telex 4232

Manica Mann George  
P O Box 460  
Blantyre

Tel. 634533  
Cable MANICA  
Telex 4134

Rennie Press (Malawi)  
P O Box 477  
Blantyre

Tel. 634755

Transport Companies

Malawi Railways  
P O Box 5144  
Limbe

Clan Transport  
P O Box 364  
Blantyre

Press Transport  
P O Box 51141  
Limbe

United Transport  
P O Box 176  
Blantyre

Tel. 631005  
Cable UNITED  
Telex 4152

Air Malawi  
P O Box 84  
Blantyre

Kamata Transport  
P O Box 856  
Blantyre

Roadmarc  
P O Box 5195  
Limbe

Main  
Features  
of Customs  
Regulations

1. Basis of value for duty is the cif price of the goods at the Malawi border.
2. Surtax of 20% on top of the duty-paid value is charged on certain goods, on which customs duty paid is more than 5%. However, surtax is not charged on hoes and on single-furrow mouldboard ploughs of a weight not exceeding 55kg. each.
3. Import licences are not required for agricultural tools or machinery, if imported from ACP, EEC, GATT & Commonwealth countries.
4. A cash deposit of 20% of the cif value of all imported goods must be lodged at the same time as the application for foreign exchange is made by the Malawi importer.
5. Combined forms of invoices and certificates of origin are required and are obtainable from most stationers.

Customs Tariff

CODE	ITEMS	TARIFFS	
		EEC, ACP, GATT and Commonwealth Origin	Others' origin
82.01.01	Hoes other than hoe blanks*	20%	30%
82.01.02 - 82.01.99	Hand tools, the following: spades, shovels, picks, hoes, forks, rakes, axes, billhooks and similar hewing tools, scythes, sickles, hay knives, grass shears, timber wedges and other tools of a kind used in agriculture, horticulture or forestry ...	5%	10%
84.10.02	Pumps, industrial or specialised for water supply, sewerage, drainage or irrigation	5%	10%
84.24.02	Single-furrow mouldboard ploughs of weight not exceeding 55kgs.	20%	25%
84.24.03 - 84.29	Agricultural, horticultural and forestry machinery for soil preparation or cultivation, harvesting and threshing machinery, fodder presses, mowers, winnowers, grading machinery, dairy machinery; parts for ploughs 84.24.02	5%	10%

\* and in addition to duty, a charge of K5.00 per 100

Source: Department of Customs & Excise, Blantyre

# SWAZILAND

**Agriculture** Swaziland has a population of about half a million, most of them living in rural areas, the only two significant towns being Mbabane and Manzini. Land is divided into two categories, a division dating from colonial times. 56% is owned by the king and this 'Swazi Nation Land' is allocated by the chiefs to each family wanting land for subsistence use. Individual freehold (title deed) land occupies the other 44% of the country, and is divided into about 450 large farms, many owned by companies or non-residents.

Thus some 35,000 smallholdings on Swazi Nation Land, most of them less than 5 hectares, coexist alongside large commercial farms, some of which are ranches of over 10,000 hectares. The table below shows area and production of principal crops in 1975.

Area and production of crops, by sector, Swaziland, 1975

Crop	Swazi Nation Land		Title Deed Land	
	Hectares	Tonnes	Hectares	Tonnes
Maize	60,999	87,961	4,948	5,950
Sugarcane	131	13,970	18,080	1,227,499
Cotton	11,336	9,903	6,247	6,820
Groundnuts	5,808	2,503	none	none
Sorghum	3,447	2,316	7	4
Beans	1,682	1,209	210	189
Tobacco	260	254	35	21
Citrus	none	none	2,349	53,983
Rice	none	none	1,613	4,418

Land Use, Swaziland, 1976/77 (hectares)

Category	Total	Swazi Nation Land	Title Deed Land
Cropland	153,015	97,323	55,692
Grazing	1,239,669	829,128	410,541
Forestry (Commercial)	97,009	-	97,009
Other	237,423	72,082	165,341
Total	1,727,116	998,533	728,583

Source: (Both tables) Rural Technology Meeting, Arusha - 1977  
Swaziland Country Paper, Unpublished.

## Technology

It is difficult to identify the numbers of implements in use or imported or exported, as separate figures are not available. However, in 1977 Swaziland imported £1.8 million worth of agricultural machinery, of which about £0.5m was for tractors. Around 200 tractors are imported each year, mainly for the large commercial farms, but there is some tractor-hiring by better-off smallholders. Most imports come from South Africa, by which Swaziland is almost completely surrounded.

Swaziland has a growing manufacturing sector, exporting televisions to South Africa and recently to Nigeria also. A parastatal corporation manufactures the 'Tinkabi' tractor, a small 16HP machine of which some 500 have now been made in Swaziland, and in which several African countries have expressed an interest.

Swaziland does not have a separate government body dealing with Appropriate Technology, but discussions have been held on establishing such a committee as part of the National Research Council.

## Transport

Swaziland has a railway to the port of Maputo in Mozambique, a distance of about 140 miles. A new rail link is currently under construction to join up with the South African Railway at Golel, to the south-east of Swaziland; this will connect Swaziland to the port of Richards Bay. The existing railway was built to handle the export of iron ore, which is now declining, though traffic in pulpwood, fruit and sugar has replaced it to some extent. Traffic to Swaziland through South Africa has to be transhipped from rail to road at Piet Retief or Barberton. Despite this, much of Swaziland's imports comes through Durban, as logistical problems at Maputo can cause delays. Also, few ships from Maputo call at East African ports, most of them going to or coming from the south. The quickest export route is road/rail to Johannesburg, then containerisation and by rail to Cape Town. Because of legislation to protect South African Railways, permits are required for road transport from Swaziland through South Africa, and these permits are only issued 'one-off'.

Manzini airport is not large enough to take large cargo planes; airfreight therefore requires a truck to take the goods from Swaziland to Jan Smuts airport in Johannesburg. Nonetheless, it sometimes comes out cheaper to airfreight even quite heavy consignments to certain places, when account is made of the various logistical problems and other factors. For example, sea-freight of a Tinkabi tractor to Nigeria costs more than twice as much as it does to India.

## Agents

Kuhne & Nagel  
PO Box A180  
Mbabane  
Tel. 4-3011 & 4-2091  
Telex 2046 WD

Freight Services (Swaziland) Ltd  
PO Box 31  
Manzini  
Tel. 52137  
Cable 'FREIGHTS'  
Telex 2065 WD

Rennies Consolidated  
Box 109  
Manzini

Main  
Features  
of Customs  
Regulations

1. With Botswana and Lesotho, Swaziland is a member of the South African Customs Union, with the Republic of South Africa.
2. The basis of valuation for duty is the 'normal price of the goods to the importer'. This is 'calculated on the basis of a sale thereof, at the time of entry for home consumption in the open market ... by any person to any other person both such persons being independent of each other ...'; it is in effect the f.o.b. price.
3. Where both a percentage rate and a specific rate are shown, the higher is the operative rate.
4. A commercial invoice and bills of lading are required for all commercial consignments; the consignee usually stipulates the number of copies. Certificates of origin, the forms for which are available from commercial stationers, are required if preferential duty is to be claimed. No facsimile signatures are permitted.
5. An import surcharge of 7½% (on the normal price) is levied on goods imported, but with the following exceptions - plough shares, plough parts, harvesting machinery, combines, fodder presses and egg-grading machines.
6. Import licences are required for all goods except those on a 'free-list' - this is signified in the tariffs below.

Customs Tariffs

CODE	ITEM	TARIFF
82.01	Hand tools for agriculture, horticulture, or forestry	
82.01.10	Axes:+	
.10	Hatchets with steel handles	20%
.90	Others	3%
82.01.20	Grub hoes+	30%
82.01.30	Picks and mattocks	25% or 30¢ each
82.01.40	Forks:	
.10	Forks with 8 or more prongs	15%
.20	Grub forks	Free
.30	Others, with prong length exceeding 150mm	15% or 30¢ each
.90	Others	Free
82.01.90	Others (i.e. other hand tools)	Free
84.24	Agricultural and horticultural machinery for soil preparation or cultivation (for example ploughs, harrows etc):	

84.24.10	Ploughs, mouldboard type (excluding reversible type) with two or more but no more than 4 shares, designed for use with tractors	15%
84.24.15	Ploughs, disc type, with 2 or more but not more than 5 discs, designed for use with tractors	15%
84.24.50	Other ploughs	Free
84.24.55	Plough shares (angle & flat)*	20%
84.24.57	Plough discs	Free
84.24.60	Parts of ploughs (except disc and shares)*	15%
84.24.70	Harrows, offset disc type, of a width not exceeding 2m., designed for use with tractors	15%
84.24.75	Harrows, one-way disc type, of a width not exceeding 2.6m., designed for use with tractors	15%
84.24.80	Other harrows	Free
84.10.40.90	Reciprocating pumps driven by compression engines	15%
	Reciprocating pumps not driven by such engines.	Free
84.10.50.10	Centrifugal and submersible pumps, bore less than 200 mm.	20%
84.24.87	Fertiliser distributors and manure spreaders	Free
84.24.90	Other agricultural or horticultural machinery for soil preparation or cultivation	Free
84.25	Harvesting and threshing machinery:	
84.25.10	Harvesting and threshing machinery*	Free
84.25.15	Combines*	Free
84.25.20.10	Power-operated straw and fodder presses*	Free
.90	Other straw or fodder presses	Free
84.25.40	Hay or grass mowers (excluding lawn mowers)	Free
84.25.50	Winnowing and cleaning machines for seed, grain or leguminous vegetables	Free
84.25.80	Egg-grading machines*	Free

+ No import license

\* No import surcharge

Source: Department of Customs and Excise, Mbabane.

# TANZANIA

Agriculture Tanzania has a population of about 15 million, of whom 13 million live in rural areas, the great majority of them in farming households. The land area of Tanzania totals 884,000 square kilometres, utilised as follows:

Smallholder cultivation	39,000 sq.kms.
Large scale agriculture	6,000
Grazing land	442,000
Woodlands, light forests	377,000
High altitude forests	4,000
Urban, rocky & swampy areas	<u>16,000</u>
	884,000 sq.kms.
	=====

Thus most cultivated land is worked by smallholders. In 1976, only about 10% of smallholding households possessed an ox-plough, most of the rest relying on hand-tools for cultivation. A few areas have tractor-hire services, but otherwise mechanisation is restricted to the large-scale farms, growing mainly export crops such as sisal, coffee, tobacco and tea, as well as crops such as wheat and sugar-cane for home consumption. The table below gives details of crop production for 1975/76.

## Crop production, exports and share of output, Tanzania, 1975/76

Crop	Hectares grown	Production (metric ton)	Export (metric ton)	% output grown by smallholders (10has or less)
Cotton	)	41,998	47,693	100
Coffee	) Not avail-	53,359	61,395	75
Tobacco	) able	18,700	2,693	75
Sisal	207,513	116,174	96,232	3
Cashew	NA	97,328	97,328	100
Maize	1,200,000	1,100,000	none	90
Paddy rice	240,000	64,000	none	80
Millet	500,000	30,000	none	100
Wheat	32,000	20,000	none	15

Source: Rural Technology Meeting, Arusha, 1977 - Tanzania Country Paper. Unpublished.

The government's 'villagisation' policy has resulted in the concentration of most of the rural population in new villages over the past decade; accurate country-wide figures on the distribution of landholdings are not available, but variations in the size of holding are not large.

Technology Tanzania produces large quantities of agricultural equipment, but also imports it. Its general policy towards mechanisation is that selective tractorisation is needed, but that

it must be backed up by maintenance, spare parts and effective utilisation - in 1977 it was estimated that 30-40% of the tractors in the country were not working due to mechanical problems. But the main focus is on animal-power, and to this end plans are well-advanced for the construction of two new factories, at Mbeya and at Mwanza, to supplement the production from Ubungo Farm Implements at Dar-es-Salaam. This corporation started in 1969. Most of the production recorded in the table below is by UFI.

Production, Imports and Stock of Agricultural Equipment, Tanzania  
1976 and 1978

Implement	1976		1978		1975 No. in use (estimate)
	Local Production	Imports	Local Production	Imports	
Ox-plough (1 furrow)	10,000	NA	7,000	NA	116,000
Ox-plough (2 furrow)	80	NA	3	NA	none
Ox-harrow	10	200	NA	NA	1,576
Ox-planter	40	NA	6	NA	128
Ox-cultivator	40	350	8	400	204
Ox-ridger	20	300	NA	NA	344
Ox-carts	1,000	none	300	none	989
Plough chains	233,952	none	81,000	none	119,000
Maize sheller	NA	1,700	NA	NA	360
Maize Mill	224	NA	603	NA	NA
Winnower	NA	NA	NA	NA	130
Groundnut sheller	84	none	3	none	187
Hoes	350,000	1,256,000	500,000	1,662,000	5,200,000
Panga	300,000	750,000	NA	345,000	2,440,000
Axe	80,000	3,000	NA	355,000	1,800,000
Grass Slasher	41,500	NA	77,000	NA	NA
Tractors	none	331	none	275(1977)	5,000
Tractor equipment	none	787	none	357(1977)	NA

(NA = not available)

- Sources: (a) Ubungo Farm Implements, Dar-es-Salaam.  
(b) 'Promotion of Rural Implements Manufacture' - J. Mueller, Copenhagen, 1977.

We should also note that, as in all the countries in the region, large numbers of implements, especially hoes, pangas and axes, are made by village artisans from scrap steel. A programme for the development of Rural Craft Workshops, of which there are currently six, is now under way, and it is planned that these will also supplement the factory production of equipment, especially that which requires an assembly operation, such as ox-carts. A major producer of such carts at present is the Tanzania Agricultural Machinery Testing Unit (TAMTU), near Arusha, where new equipment is developed and imports are tested. Tractors and tractor equipment are imported by private

dealers and by a corporation, AISCO, under conditions laid down by AISCO. Animal-drawn implements and hand-tools are imported solely by UFI.

Also shown in the table above is an estimate of the numbers of implements actually in use in 1976; however this is a very broadly based estimate.

## Transport

Tanzania borders seven countries, shares a mid-lake border with an eighth and also has access to the sea. It is thus well-placed for regional trade, and to act as a transit corridor for other countries.

The new TAZARA railway links the port of Dar es Salaam with the Zambian railway at Kapiri M'poshi (though trans-shipment is necessary as the gauges are different). Tanzania's older railway system links Dar es Salaam with Kigoma on Lake Tanganyika, whence goods can be ferried to Burundi and Zaire, and with Mwanza on Lake Victoria, from where goods can be ferried to parts of Uganda. The railway link from Moshi into Kenya is at present closed, as are the road links with Kenya.

Both rail and road are used for the heavy traffic between Zambia and Dar es Salaam, and for traffic to and from Burundi and Rwanda. In 1978, 850,000 tons of goods were carried between Zambia and Tanzania on the railway, and a further 226,000 tons by road.

Transit goods through Tanzania must be covered by a bond equivalent to the customs value of the goods in Tanzania, but this bond security is waived for the main authorised agents/carriers.

There is a road link between Tanzania and Malawi, via Katumbi and Tunduma in Zambia.

The port of Dar es Salaam is linked more with the northern ports on the east African coast than it is with the southern ports such as Maputo, but there are boats to Mozambique ports.

## Agents

East African Transport Ltd  
Box 991  
Dar es Salaam  
Tel. 21170  
Cable EATRACO

Maritime Forwarders  
Box 4537  
Dar es Salaam  
Tel. 258715  
Cable FORWARDERS  
Telex 41020

Express Tanzania Ltd  
Box 884  
Dar es Salaam  
Tel. 22401  
Cable EXPRESS  
Telex 41041

AMI Tanzania  
Box 9041  
Dar es Salaam  
Tel. 31011  
Cable AGENMAREST  
Telex 41008

Freight Express  
Box 3510  
Dar es Salaam  
Tel. 29224  
Cable FECO

Transport Companies	Karibafreight Box 4367 Dar es Salaam Tel. 26031 Cable KARIBA Telex 41073	Zambia-Tanzania Road Services Box 2512 Dar es Salaam  National Shipping Agencies Box 9082 Dar es Salaam
	Jashbhai Patel & Co Box 252 Dar Es Salaam Tel. 22066	Tel. 27241 Cable NASACO Telex 41235

Main  
Features  
of Customs  
Regulations

1. No preferences.
2. The value for duty purposes is the c.i.f. price of the goods. For goods imported by air, only 50% of the air freight element is counted towards the dutiable value.
3. A sales tax is levied on the duty-paid value of many goods, but most articles listed in this guide are free of sales tax.
4. All goods imported into Tanzania must be insured with the National Insurance Corporation of Tanzania.
5. Most of the goods listed in this guide can only be imported through specified parastatal organisations such as the National Development Corporation, the Agricultural and Industrial Supplies Co Ltd., or Ubungo Farm Implements Ltd.
6. All imports into Tanzania are subject to quantity, quality and price inspection before shipment, except for goods with a value in pro-forma invoice of less than Tshg.20,000 unless in part shipments, or goods produced by international tender or through the Crown Agents.

Customs Tariffs

CODE	ITEM	TARIFF
82.01	Hand tools, the following: spades, shovels, picks hoes, forks and rakes; axes, bill hooks and similar hewing tools; scythes, sickles, hay knives, grass shears, timber wedges, and other tools of a kind used in agriculture	Free
	of a kind used in horticulture or forestry	10%
82.02	Saws (non-mechanical) and blades for hand or machine saws, other than butchers saws	10%
	Butchers saws	30%
84.24 - 84.27	Agricultural and horticultural machinery for soil preparation or cultivation (for example, ploughs, harrows, cultivators, seed and fertiliser distributors; agricultural and horticultural machinery	

	for harvesting and threshing and sorting and cleaning; dairy machinery; presses and crushes	10%
84.28 A	Plates mills and hammer mills	15%
84.28 B	Other agricultural machinery, and horticultural, beekeeping, poultry-keeping machinery etc	10%
84.29	Machinery of a kind used in the bread grain milling industry and other machinery (other than farm type machinery) for the working of cereals or dried leguminous vegetables	10%
84.30	Other food processing machinery (excluding domestic)	10%
	Other food processing machinery	30%
84.10	Pumps	NA

Source: Customs and Excise Department - Dar-es-Salaam.

# UGANDA

**Agriculture** According to a team of Commonwealth experts, which reviewed the state of Uganda's economy after the Liberation War, between 1970 and 1978 production of tea was halved, production of cotton fell from 76,000 to 11,000 tons, and production of sugar dropped from 144,000 tons to 12,000 tons. During the war, the only factory for farm implements was almost destroyed and then looted, and the production of this factory was anyway far below that needed to substitute for imports.

Reliable figures on the value of agricultural production are not available. The table below gives rough estimates of the shares of agricultural output in 1976, for selected crops.

Value of crop production by large and small farmers, Uganda, 1976

Production	Value in Shs. Million	Small-Scale Farmers %	Large-Scale Farmers %
Coffee	2,510	95	5
Cotton	200	100	0
Tea	89	40	60
Sugar & Jaggery	27	55	45
Tobacco	15	100	0
Grade beef cattle	250	0	100
Grade dairy cattle	105	25	75
Traditional cattle			
- beef	900	90	10
- dairy	595	90	10

Source: 'The Rehabilitation of the Economy of Uganda,' report by a team of Commonwealth Experts, Commonwealth Secretariat, 1979.

Figures on land ownership are not available, but it is clear that illegal sales or gifts of public land to private individuals were common in the past decade; these large estates are often now abandoned or their ownership is in dispute. But on the whole Uganda remains, as it has always been, a country of smallholders, with the large-farm sector playing a smaller role than, for example, in neighbouring Kenya.

**Technology** The Commonwealth team estimated that 5 million hoes were required immediately, in mid-1979. The EEC provided a grant to purchase 1 million, and if the steel is available the 1980-81 Ugandan manufacturing capacity is about 1 million/year. The UNIDO low-cost farm equipment project, which before the war was producing limited quantities of ox-ploughs, ox-carts and hammer mills, required 6 million shillings for its rehabilitation. The main producer of hand-tools is Uganda Hoes Ltd, where production of 1.5 million hoes in 1970 had fallen to 332,000 in 1978; in

that year, an estimated 400,000 hoes were imported. Capacity at that factory is 1.5 million hoes per annum, about the same as estimated national demand.

In 1977 UNICEF and the Ministry of Agriculture & Forestry agreed to set up a Village Technology Resource Centre, to be constructed near Kampala as a demonstration and training centre which would also do R&D work on village technologies.

#### Transport

Uganda is land-locked, but it has potentially good road, rail, lake and river transport infrastructure with all its five neighbours: Kenya, Tanzania, Rwanda, Zaire and Sudan. In recent years there has been a restriction in the use of these routes, first in the border conflict with Tanzania, and later in the Liberation War.

Presently the Sudan border is not open, and the land border with Tanzania has a limited capacity for freight, as the road connections between Mwanza and Masaka through Bukoba are difficult. A lake steamer service connects Tanzania with Uganda via Mwanza - Port Bell and there are also air services; Road transport between Rwanda and eastern Zaire and Uganda has operated regularly throughout, and at Kampala these routes join Uganda's main route to the coast - the Kampala/Nairobi/Mombasa road.

This latter route is also served by the main railway line of Uganda/Kenya Railways between Kampala and Mombasa, and this road and rail link is probably the most reliable for trade between Uganda and other countries of the region except Tanzania.

#### Agents

Agence Maritime Internationale  
Box 7043  
Kampala  
Tel. 42116

Samtanus International Freight Forwarders  
Box 5914  
Kampala  
Tel. 58674  
Cable SAMTANUS  
Telex 61133 UG

#### Transport Companies

Comet Freight and Travel  
c/o T A Bhatt  
Box 5138  
Kampala  
Tel. 3303

Express Transport  
PO Box 7194  
Kampala  
Tel. 41210  
Telex 61026

Kenatco Transport  
PO Box 687  
Kampala  
Tel. 57186

#### Main features of customs regulations

1. No details are available of tariff rates and as foreign exchange control is a more important factor, considering the highly acute shortage faced by Uganda, information

about this is probably more useful.

2. The current (1980) ration of foreign exchange for all private sector imports is £10 million per month. All intending importers must apply for a foreign exchange allocation with a pro-forma invoice from the supplier.
3. Import licences are also required. The Ministry of Commerce will issue import licences through a Committee. They will be valid for one year and be issued only for the following categories of goods:
  - (i) Raw materials, spares, agricultural items, passenger and industrial vehicles, pharmaceuticals, consumer goods, educational materials.
  - (ii) Imports on behalf of parastatals, industries, oil-companies and suppliers of the consumer market in rural areas.
4. All import business will be conducted by documentary letters of credit.

# ZAMBIA

## Agriculture

With more than two million of its five million population living in towns, Zambia is the most urbanised of the Commonwealth countries in the region. The economy is dominated by the copper industry, and the lines of communication reflect this dominance, with rail links from the copperbelt to ports in the east, south and west but less effective communication with the agricultural areas. In 1978, 717,000 tonnes of exports were complemented by 654,000 tonnes of imports. The general position of Zambia as regards imports and exports will be greatly affected by developments in Zimbabwe.

About 70% of Zambia's rural population farm smallholdings of less than 2 hectares, and a further 20% have farms of between 2 and 5 hectares. There is also a large-farm sector, with 4,700 farms over 20 hectares, and it is on these that most of the tractors in the country are to be found.

The principal crop is maize, with an average annual production of around 1.2 million tons, of which about 750,000 tons are marketed. An estimated 415,000 hectares of maize were planted in 1976, compared to 67,000 hectares of groundnuts, the next largest crop. Figures are given below:

Crop	Area (1976) hectares	Production (1976) tons
Maize	415,000	1,260,000
Groundnuts	57,000	46,000
Sunflower	19,300	20,000
Tobacco	8,314	6,478
Sugarcane	7,156	779,611 (cane)
Cotton	6,000	3,000 (seed)
Rice	2,200	2,200

Source: Rural Technology Meeting, Arusha - 1977. Zambia country paper unpublished.

## Technology

There are no precise figures on the amount or type of agricultural equipment now in use, but about 800 tractors are imported each year, and until recently about 15,000 ox-drawn ploughs were being imported also, along with a variety of ox-drawn equipment, and about 200,000 hoes for hand cultivation. Until recently very little equipment was produced locally, but now an order for 5,000 ox-drawn ploughs has been completed by a local firm for NAMBOARD, which is the major importer and distributor of non-tractor equipment. The importation of ox-drawn ploughs has recently been banned. Maize mills, trailers and water bowsers have

been locally manufactured for some time. One encouragement to local manufacture is the AGMAC award for the best local agricultural machinery, and for the most promising prototype.

Zambia has a National Appropriate Technology Committee, which is chaired by the Permanent Secretary of the National Commission for Development Planning; it has subcommittees on agriculture, industry, research and on community development, chaired by officers appointed by the respective Permanent Secretaries.

At Magoye there is a Farm Machinery Research Unit, which tests equipment for its suitability for use in Zambia; it cooperates closely with Zambian manufacturers, suggesting improvements in design or fabrication of local equipment. There is also currently a UNDP/FAO project to set up Village Workshops with trained artisans, for in Zambia as elsewhere local blacksmiths provide many tools which go unrecorded in the official statistics.

Production & imports of equipment, Zambia, 1976

Equipment	No, manufactured	No. imported
Tractors	none	848
Tractor implements	none	1,600
Ox-ploughs	none	15,000
Ox-harrows	none	3,000
Ox-planter	none	1,000
Hoes	50,000	200,000
Other hand tools	none	50,000
Sprayers	none	1,700
Ox-cultivators	100	300
Planters & seeders	none	300
Trailers	100	156
Harrows	2,000	none
Bowsers	100	none

Source: Rural Technology Meeting, Arusha, 1977 - Zambia Country Paper Unpublished.

Transport

Zambia is land-locked, but it also has, at least potentially, a number of alternative routes to the sea and to other countries. Before UDI its main port was Beira, using Zimbabwe as a transit route; traffic on this route declined and finally stopped in 1973, and Zambian exports via the Benguela Railway to Lobito in Angola jumped from 170,000 tons in 1972 to 438,000 tons in 1973. But in August 1975 this route was severed by the war in Angola; in August 1976 the TAZARA railway to Dar es Salaam was opened, and by late 1977 80% of Zambia's exports and 85% of its imports were coming through Tanzania. But because of the restricted capacity of the Tazara route, at the end of 1978 the railway line through Zimbabwe was re-opened to allow urgent imports

of fertiliser from South Africa, and now, in 1980, Zimbabwe's independence will change the pattern again.

Note should also be made of Zambia's road links, existing and potential. In 1978 over 200,000 tons of goods were carried by road between Zambia and Tanzania, and in the early 1980s there was also heavy road traffic between Zambia and Kenya via Tanzania. Some traffic goes to and from Mozambique via Malawi, being trucked between Zambia and Lilongwe via Mchinji, or to the railhead at Moatize in Mozambique itself. The railway is being extended from Lilongwe to the Zambian border, and Zambia has plans to extend its railway from Lusaka to Chipata.

One deleterious effect on Zambia of Zimbabwe's independence may be that Beira will be swamped by Zimbabwean goods, forcing Zambia (and Malawi) to rely more on the northern Mozambique port of Nacala.

Zambia is itself a transit country for traffic between Tanzania and Botswana; between Malawi and Botswana and other countries to the south; and for traffic between Zaire and South African ports. The route to Botswana via Livingstone and the Kazungula ferry is not likely to return to its previous status now that Zimbabwe is independent. Transit goods through Zambia require a permit which can be obtained at the border.

Agents	Agence Maritime Internationale Box 964 Lusaka Tel. 74851	J J Lowe Ltd Box 420 Livingstone Tel. 2488
	Trans-Botswana Agencies Ltd Box 420 Livingstone	Manica Freight Services PO Box Lusaka
Transport Companies	Leopold Walford (Zambia) Ltd Box 1280 Lusaka Tel. 75041	Jukes Curtis Transport Ltd PO Box 695 Lusaka Tel. 73009
	Zambia-Tanzania Road Services Box 2581 Lusaka Tel. 74861	Contract Haulage Ltd Box 105 Lusaka Tel. 74251
	Livingstone Customs & Transport Co Ltd Box 178 Livingstone	
	Kariba Freight Box 1820 Ndola Tel. 3139	
Main Features of Customs Regulations	<ol style="list-style-type: none"><li>1. Basis of value for duty is the f.o.b. price to the importer.</li><li>2. A tax of 2% is levied on all import licenses.</li><li>3. A sales tax of 10% is levied on all dutiable goods;</li></ol>	

however, the taxable amount on which this 10% is calculated is not the value for duty purposes, but the value for duty purposes plus 20% of that value, plus the import duty itself, plus 25% of the sum. Roughly speaking, the 10% sales tax works out at a 15-20% tax on FOB value.

4. Foreign exchange is issued on a quota basis, and import licences are required for all imports. In the case of agricultural tools and ox-drawn implements, NAMBOARD are the sole importers.
5. A prescribed form of invoice and certificate of origin and of value is required for all imports. It is obtainable from stationers. The original form plus 4 copies should be sufficient.
6. Certain goods imported into Zambia must be inspected before shipment.
7. Goods trans-shipped at Dar es Salaam should include on their invoice the Customs Cooperation Council Nomenclature tariff numbers for the goods in question.

#### Customs Tariffs

CODE	ITEM	TARIFF
82.01.00	Hand tools, the following: spades, shovels, picks, hoes, forks, rakes, axes, billhooks, scythes, sickles, hay knives, grass shears, timber wedges, other tools of a kind used in agriculture, horticulture or in forestry	Free
84.10.00	Liquid elevators of the bucket, chain, screw, band and similar kind	7½%
84.10.22	Pumps for stationary engines	7½%
84.24.00 - 84.25.99	Agricultural, horticultural or forestry machinery of all kinds, (i.e. harrows, cultivators, ploughs, threshers etc) and parts thereof, with the exception of lawn mowers and rollers and motorised scythes .....	Free
84.26.00 - 84.29.10	Dairy machinery, milking machines, churns; presses, crushes and other such machinery for wine-making, cider-making, fruit juice preparation etc; other agricultural, horticultural, poultry-keeping and bee-keeping machinery, germination plant fitted with mechanical or thermal equipment, poultry incubators and brooders .....	Free
84.29.90	Machinery (other than maize grinders) of a kind used in the bread grain milling industry, and other machinery (other than farm type machinery) for the working of cereals or dried leguminous vegetables	10%
84.30.00	Machinery not falling within the above headings, of a kind used in bakery, confectionery, etc.	7½%

Source: Department of Customs & Excise - Lusaka

# ZIMBABWE

## Agriculture

The population of Zimbabwe is about 7.5 million, 80% of which lives in rural areas. A large proportion of the land of Zimbabwe is suitable for arable agriculture and livestock grazing, and there are several distinct zones related to altitude and rainfall which are suitable to different types and different intensities of agriculture.

Administratively, at Independence in 1980, the agricultural land of Zimbabwe was divided into three tenure systems:

- (1) European land - (mostly large commercial holdings)
- (2) Tribal Trust land (peasant farming areas)
- (3) African Purchase Land (available to selected African farmers)

Of these categories the European Land and Tribal Trust Land occupy most of the agricultural land, and until independence access to them was controlled on racial grounds. The African Purchase Land was available only to 'emergent' African farmers who could verify their farming ability and access to a sufficient sum of capital.

Consequently, the rural population, and the size of holding is unequally divided between these three categories of land-tenure system. The large farming area, previously designated European land, occupies 15.5m hectares of farmland and grazing, and contains only 7000 holdings. The Tribal Trust lands (TTL's) occupy 16.2m hectares of farmland and grazing and are settled by 4.64 million people, 62% of the population. Thus, including grazing land, this represents a land availability of 3.5 ha. per resident in the TTL's. The African Purchase Land consists of 8,500 holdings, but only 8% of the total APL area is cropped - most is used for livestock production.

In both the large farming areas and the TTL's also, a large proportion of the land is used for grazing livestock. About 14.0m. hectares of land in each tenure area are used for grazing, leaving the following amounts of arable land:

Large Farming area	-	1.5m. hectares
Tribal Trust Lands	-	2.2m. hectares

According to ecological classification this accords with the total amount of land naturally suited to arable agriculture, any expansion of which will require irrigation of land presently only suitable for pasture. The present Five-year Development Plan contains a provision to irrigate about 75,000 hectares of Tribal Trust Land.

The principal crops grown in Zimbabwe are: maize, wheat, tobacco, sugar-cane, millets and sorghums, groundnuts, cotton and soya beans, with tea and coffee in the highlands of the East. In the TTL's the main food crops are maize, sorghum/millet, and pulses whilst the main cash crops are maize, groundnuts and cotton.

## Technology

From this it can be seen that there is a clear divide in Zimbabwe in the demand for different types of agricultural machinery. In the Tribal Trust Lands there are 800,000 households of whom up to 700,000 have agricultural plots. As the total area of TTL arable land is only 2.2m ha., then the average size of arable holding is 3.1 ha. In the large farming sector the average size of arable holding on the other hand is 100 ha. These latter holdings are farmed with a high capital/labour ratio and there is a large domestic demand for tractors over 50 HP and tractor -drawn implements. In the Tribal Trust Lands, the majority of households farm with hand implements and these are manufactured within Zimbabwe. Normally there is also a significant use of ox-draught, although this use had temporarily fallen during the emergency; three companies manufacture a range of ox-drawn implements. Any significant increase in demand for ox-drawn machinery would depend on both increased irrigation within the TTL area, and upon any future measures of land redistribution.

There is also a small potential demand for small tractors under 30 HP in the TTLs and in the smaller tenure area of freehold in the 'African Purchase Areas.' Cultivation machinery is not the only type of machinery manufactured in Zimbabwe, and the output of the country's relatively large manufacturing sector includes a high value of agricultural machinery of all types, although this is largely for the large farming sector.

The importation of agricultural machinery and all goods into Zimbabwe is strictly controlled in order to keep a tight control over the use of scarce foreign exchange reserves. Import applications are subject to an evaluation by the Ministry of Agriculture which recommends according to the availability of alternative locally produced implements and according to the productive potential of the item to be imported.

The Institute of Agricultural Engineering, 18 km. north-west of Salisbury, tests agricultural machinery as well as conducting engineering and agronomy trials. It has recently formed an Intermediate Technology Section which gives special attention to the machinery requirements of the small farming sector. In its programme of testing of locally produced ox-drawn machinery it has developed some improved designs and it has produced a list of all low-cost tools available in Zimbabwe, with the aim of making a complete collection to which can be added appropriate additions from outside the country. The IAR also has a programme to develop alternative power sources and is working on windmills and biogas.

## Transport

Zimbabwe borders Mozambique, South Africa, Botswana and Zambia and lies across potentially important regional transport routes between Southern and Central Africa.

The Zimbabwe Railway System forms a link in a continuous line of rail between Botswana and Zambia, via Plumtree, Bulawayo and Victoria Falls. The railway also links the South African railway system at Beit Bridge, and southward to Lesotho and Swaziland.

Road transport is well developed and is served by a country-wide network of metalled roads, which also cross the Zambian border at Victoria Falls and Chirundu, the Mozambique border at Umtali and the Botswana border at Plumtree. Freight between Salisbury and Zambia and Southern Africa can now equally easily be carried by road transport or by rail transport and there are several freight companies which specialise in this.

Since independence, Zimbabwe now has direct air-links, which can be used for air-freight, with Kenya, Zambia, Malawi and Tanzania.

Goods imported and exported to and from Zimbabwe by sea freight presently use Beira, Maputo and the South African ports.

Agents	<p>Allen Wack and Shepherd P. O. Box 586 Salisbury Tel. 794311 Cable: THAINE</p>	<p>Manica Freight Services Ltd. Salisbury Tel- 760761 Cable: MANFREIGHT</p>
	<p>Mitchell Cotts Seafreight Ltd P O Pox 264 Salisbury Tel. 792666 Cable: MCTRAVEL Telex 2169</p>	<p>Freight International P O Box US372 Salisbury Tel. 708877 Cable: STEAMSHIP Telex 4348 RH</p>
Transport Companies	<p>National Railways of Zimbabwe P O Rox 582 Salisbury Tel. (Rail) 700020 (Road) 700029</p>	<p>Beattle &amp; Dore 3 Upton Road Ardbennie Salisbury Tel: 64403</p>
	<p>Freight Forwarders of Zimbabwe Ltd. P O Box 4099 Salisbury Tel. 700891</p>	<p>Air Zimbabwe P. O. Box API Salisbury Airport Salisbury Tel. 52601 Cable: AIRZIMBABWE</p>
	<p>Clan Transport Co. Ltd P O Box 2253 Salisbury Tel. 64651 Cable: CLAN</p>	<p>Swift Transport Services P O Box 772 Salisbury Tel: 64777</p>

- Main features of custom regulations
1. Duty is assessed according to the 'Brussels Definition of Value' (BDV). All goods are dutiable to the BDV value as it is assessed at the point and time of entry into Zimbabwe.
  2. The BDV is valued as the normal price on FOB basis, and allowances are made for discounts operative on quantity supplied. Theoretically the BDV should be assessed as the open market value of an item is released for sale on the Zimbabwe market at the time of entry. In practice, as long as there is no business association between the supplier and the importer, the original invoice of the supplier is acceptable as proof of value. Customs needs to retain one copy therefore of commercial invoices.

3. Where the importer is associated in business with the supplier, then the Customs Department will, in consultation with the importer, determine the price that would have been charged if the transaction had occurred on the open market.
4. Preferential rates of duty are applicable to goods originating in the Republic of South Africa, Lesotho, Swaziland, Mozambique, Angola and Portugal. These rates vary according to item and should be ascertained from the Department of Customs.
5. Imports made from these sources should be accompanied by a 'Certificate of Origin', which should be completed and signed by the manufacturer/supplier. One copy only is required.
6. Strict foreign exchange controls operate in Zimbabwe and all prospective importers are required to apply for a foreign exchange allocation. In the case of a new item of agricultural machinery this may involve the need for the item to be tested by a government department to accord it a priority.
7. Several items of agricultural machinery are not permitted against these allocations, amongst which: groundnut shellers and pickers, hammermills, ploughs, ridgers (although in the case of ox-drawn machinery it should be ascertained whether a particular item is exempt according to its technical specifications).

#### Customs Tariffs

CODE		
118 (a) (i)	Agricultural Machinery	Free
	<u>Except</u>	
118 (a) (ii)	Single furrow mouldboard ploughs having a mass not exceeding 55kg.	15%

Source: Department of Customs and Excise, Salisbury.

5. I N D E X E S

## INDEX OF MANUFACTURERS

<u>Manufacturer</u>	<u>Country</u>	<u>Pages</u>				
African Rural Storage Centre, Box 7 Chilanga	Zambia	63				
African Rural Storage Centre, Box 82694 Mombasa	Kenya	85				
Agricultural Implements Manufacturers Box 1553 Nakuru	Kenya	17	26	46		
Agrimal (Malawi) Ltd., Box 143 Blantyre	Malawi	16	21	22	27	37
		42	48	49	55	
Beekeeping Sect., Min. of Agric. Box 30028 Nairobi	Kenya	82				
Brown & Clapperton Ltd., Box 52 Blantyre	Malawi	50	58	60	67	87
Bulawayo Steel Products Ltd., Box 1603 Bulawayo	Zimbabwe	18				
Chitedze Research Station Box 158 Lilongwe	Malawi	48	51			
Component Parts (Swaziland) Ltd., Box 1087 Mbabane	Swaziland	68				
Dept. of Lands, Valuation & Water P. Bag 311 Lilongwe	Malawi	65				
Farm Machinery Research Unit, Box 11 Magoye	Zambia	47				
Bobs Harries Engineering Ltd., Box 40 Thika	Kenya	71				
Ideal Casements Ltd., Box 45319 Nairobi	Kenya	15	27			
Jandu Plumbers Ltd., Box 409 Arusha	Tanzania	72				

<u>Manufacturer</u>	<u>Country</u>	<u>Pages</u>
Kenya Engineering Industries Ltd., Box 18331 Nairobi	Kenya	25
Kgatlang Development Board, Box 208 Mochudi	Botswana	35
Kilacha Production & Training Centre, Box 21 Himo	Tanzania	79
Majengo Co-operative Group, Box 764 Arusha	Tanzania	66
Manik Engineers Ltd., Box 1274 Arusha	Tanzania	58
Mochudi Brigades, Box 248 Mochudi	Botswana	44
Ndume Ltd., Box 62 Gilgil	Kenya	57 60
Ngolo Industries Ltd., c/o Box 5052 Lilongwe	Malawi	88
Northland Engineering Ltd., Box 1640 Ndola	Zambia	18
Ploughs & Allied Products Ltd., Box 467 Kisumu	Kenya	15 21 32 70 88
John Rau & Co. Ltd., Box 2893 Salisbury	Zimbabwe	83
Rhoplow Ltd., Box 1059 Bulawayo	Zimbabwe	20 23 28 40
Rural Industries Innovation Centre, P. Bag 11 Kanye	Botswana	61

<u>Manufacturer</u>	<u>Country</u>	<u>Pages</u>				
Save the Children Vocational Workshop, Box MS 286 Maseru	Lesotho	80				
SISCOMA BP 3214 Dakar	Senegal	17	29	30	31	33
		34	38	41	42	43
		49	52	53	54	55
		68	86	87		
Tanzania Agric. Machinery Testing Unit, Box 1389 Arusha	Tanzania	19	39	45	85	
Tengeru Furniture Mart, P. O. Duluti Arusha	Tanzania	81				
Tinkabi Tractor Project, Box 450 Manzini	Swaziland	36				
Tunnel Co. Ltd., Private Bag Fort Ternan	Kenya	75	76			
Ubungo Farm Implements Ltd., Box 20126 Dar-es-Salaam	Tanzania	16	26	50		
Uhandisi Co-operative Society, Box 849 Arusha	Tanzania	77				
Ujuzi Leo Industries, Box 7146 Arusha	Tanzania	69				
United Engineering Works Ltd., Box 3082 Arusha	Tanzania	59	81			
Warren Engineering Ltd., Box 30151 Nairobi	Kenya	73				

## INDEX OF TOOLS AND IMPLEMENTS

<u>Type</u>	<u>Example</u>	<u>Page No.</u>
<u>Beehives</u>	Kenya Top-Bar Hive	82
	Rau Langstroth Hive	83
	Tengeru Beehive	81
<u>Beekeeping Equipment</u>	Beekeeping Section, Kenya	82
	Honey Press, United Engineering	81
	Rau Equipment	83
<u>Bowers</u>	Siscoma Bowser	86
<u>Cultivators</u>	Agrimal 5-Tine	22
	Agrimal Standard	21
	PAP Universal	21
	Rhoplow 5-Tine	23
<u>Groundnut Lifters</u>	Agrimal Lifter	48
	Bornu Lifter	47
	Chitedze Lifter	48
<u>Groundnut Threshing &amp; Shelling</u>	Agrimal Sheller	49
	Chitedze Pod-Cracker	51
	Siscoma Alternating Sheller	53
	Siscoma Pod-Stripper	53
	Siscoma Rotary Thresher	52
	Siscoma Senegal Screen Sheller	52
UFI Sheller	50	
<u>Hand-Tools</u>	Agricultural Implements, Nakuru	26
	Agrimal	27
	Ideal Casements	27
	Kenya Engineering	25
	Rhoplow ("Mealie" Brand)	28
	UFI	26
<u>Harrows</u>	Agrimal Diamond	37
	Agrimal Triangular	37
	Agrimal Zig-Zag	37
	Rhoplow Diamond	40
	Rhoplow Triangular	40
	Rhoplow Zig-Zag	40
	Siscoma Rotary	38
	Siscoma Zig-Zag	38
TAMTU Rectangular	39	
<u>Horse/Donkey Carts</u>	Siscoma Cart	86
<u>Hydrans</u>	Jandu Hydram	72
<u>Incubators</u>	Kilacha Incubator	79

<u>Type</u>	<u>Example</u>	<u>Page No.</u>
<u>Methane Generators</u>	Hutchison Generators	75
	Uhandisi Generators	77
<u>Mills For Grain</u>	Atom Maize Mill	58
	Dunia Hand Mill	60
	Kusinja Maize Mill	60
	Manik Maize Mill	58
	Ndume Maize Mill	57
	RIIC Sorghum Mill/Thresher	61
	United Maize Mill	59
<u>Ox-Carts</u>	B + C Ox-cart	87
	Ngolo Ox-cart	88
	Siscoma Ox-cart	87
<u>Paddy Threshers</u>	Agrimal Thresher	55
	Siscoma Thresher	54
<u>Palm-Nut Crackers</u>	Siscoma Cracker	55
<u>Persian Wheel</u>	Jandu Persian Wheel	72
<u>Planters</u>	Agrimal Ox-drawn Planter	42
	B + C Hand-planter	46
	Mochudi Ox-drawn Planter	44
	Rotary Injection Planter	46
	Siscoma Donkey-drawn Paddy Pltr.	41
	Siscoma Hand-operated Paddy Pltr.	41
	Siscoma Paddy/Wheat Planter	42
	Siscoma Super-Eco Ox-drawn Pltr.	43
	TAMTU Hand-planter	45
TAMTU Ox-drawn Planter	45	
<u>Ploughs</u>	Agric. Implements Mouldboard	17
	Agrimal Mouldboard	16
	BSP Silver Medal Mouldboard	18
	Ideal Casements Mouldboard	15
	Kifaru Plough	19
	Northlands Mouldboard	18
	PAP Mouldboard	15
	Rhoplow 2-furrow	20
	Rhoplow Single-furrow	20
	Siscoma Mouldboard	17
	UFI Mouldboard	16
<u>Ridgers</u>	Agrimal Ridger	22
	Rhoplow Ridger	23
<u>Shellers</u>	Agrimal Groundnut Sheller	49
	B + C Maize Sheller	50
	Siscoma Alternating G'nut Sheller	53
	Siscoma Senegal Screen G'nut "	52
	Siscoma Maize Sheller	49
UFI Groundnut Sheller	50	

<u>Type</u>	<u>Example</u>	<u>Page No.</u>
<u>Solar Water-Heaters</u>	Hutchison Heater	76
<u>Spinning-Wheels</u>	Mohair Spinning-Wheel	80
<u>Storage Structures</u>	Ferrumbu Maize-Bin	63
<u>Threshers</u>	Agrimal Paddy Thresher	55
	RIIC Sorghum Thresher/Mill	61
	Siscoma Groundnut Pod-stripper	53
	Siscoma Groundnut Thresher	53
	Siscoma Paddy Thresher	54
<u>Tool-Bars</u>	Magkonasothle Tool-Bar	35
	PAP Sine Tool-Bar	32
	Siscoma Arara Tool-Bar	30
	Siscoma Ariana Tool-Bar	33
	Siscoma Baol Tool-Bar	34
	Siscoma Greco Tool-Bar	32
	Siscoma Occidentale Tool-Bar	29
	Siscoma Sine Houe Tool-Bar	31
<u>Tractors</u>	Tinkabi Tractor	36
<u>Water-Pumps</u>	B + C Water Pumps	67
	Brisan Submersible Pump	68
	Lands/Valuation Malawi Pump	65
	Majengo Pump	66
	Siscoma Gueroult Pump	68
<u>Water-Tanks</u>	Warren Water-Tanks	73
<u>Wheelbarrows</u>	Afsteel Wheelbarrow	85
<u>Wheels</u>	PAP Ox-cart Wheels	88
<u>Windmills</u>	Arusha Windmill	69
	Kijito Windmill	71
	PAP Dragon Windmill	70
<u>Winnowers</u>	Siscoma Cueme Winnower	54

© Copyright 1981

Printed and published by  
The Commonwealth Secretariat

May be purchased from  
Commonwealth Secretariat Publications  
Marlborough House  
London SW1Y 5HX

ISBN 0 85092 198 8

